

SECTION **SE**
SEAT

A
B
C
D
E
F
G
H
SE
J
K
L
M

CONTENTS

PRECAUTIONS	3	Terminals and Reference Values for BCM	32
Precautions for Supplemental Restraint System (SRS) "AIR BAG" and "SEAT BELT PRE-TENSIONER"	3	Trouble Diagnosis	32
Precautions for Work	3	WORK FLOW	32
PREPARATION	4	PRELIMINARY CHECK	32
Special Service Tool	4	CONSULT-II FUNCTION	35
Commercial Service Tool	4	CAN COMMUNICATION INSPECTION USING CONSULT-II (SELF-DIAGNOSIS)	39
SQUEAK AND RATTLE TROUBLE DIAGNOSES	5	SYMPTOM CHART	40
Work Flow	5	SEAT SENSOR POWER SUPPLY AND GROUND INSPECTION	42
CUSTOMER INTERVIEW	5	SLIDING MOTOR CIRCUIT INSPECTION	43
DUPLICATE THE NOISE AND TEST DRIVE	6	RECLINING MOTOR CIRCUIT INSPECTION	44
CHECK RELATED SERVICE BULLETINS	6	FRONT LIFTING MOTOR CIRCUIT INSPECTION	45
LOCATE THE NOISE AND IDENTIFY THE ROOT CAUSE	6	REAR LIFTING MOTOR CIRCUIT INSPECTION	47
REPAIR THE CAUSE	6	MIRROR MOTOR LH CIRCUIT INSPECTION	48
CONFIRM THE REPAIR	7	MIRROR MOTOR RH CIRCUIT INSPECTION	50
Generic Squeak and Rattle Troubleshooting	7	STEERING WHEEL TELESCOPIC CIRCUIT INSPECTION	51
INSTRUMENT PANEL	7	STEERING WHEEL TILT CIRCUIT INSPECTION	53
CENTER CONSOLE	7	SLIDING SENSOR CIRCUIT INSPECTION	55
DOORS	7	RECLINING SENSOR CIRCUIT INSPECTION	56
TRUNK	8	FRONT LIFTING SENSOR CIRCUIT INSPECTION	57
SUNROOF/HEADLINING	8	REAR LIFTING SENSOR CIRCUIT INSPECTION	58
SEATS	8	MIRROR SENSOR LH CIRCUIT INSPECTION	59
UNDERHOOD	8	MIRROR SENSOR RH CIRCUIT INSPECTION	60
Diagnostic Worksheet	9	DETENTION SWITCH CIRCUIT INSPECTION (A/T MODEL ONLY)	61
AUTOMATIC DRIVE POSITIONER	11	PARKING BRAKE SWITCH CIRCUIT (M/T MODEL ONLY)	63
System Description	11	STEERING WHEEL TELESCOPIC SENSOR CIRCUIT INSPECTION	64
OPERATIVE CONDITION	11	STEERING WHEEL TILT SENSOR CIRCUIT INSPECTION	65
SYSTEM DESCRIPTION	11	KEY SWITCH AND KEY LOCK SOLENOID CIRCUIT INSPECTION	66
Component Parts and Harness Connector Location	16	FRONT DOOR SWITCH (DRIVER SIDE) CIR-	
Schematic	17		
Wiring Diagram-AUT/DP-	19		
Terminals and Reference Values for Driver Seat Control Unit	28		
Terminals and Reference Values for Automatic Drive Positioner Control Unit	30		

CUIT INSPECTION	68	Schematic	89
SEAT MEMORY SWITCH CIRCUIT INSPECTION	69	Wiring Diagram–SEAT–	90
SLIDING SWITCH CIRCUIT INSPECTION	71	HEATED SEAT	93
RECLINING SWITCH INSPECTION	72	Description	93
FRONT LIFTING SWITCH CIRCUIT INSPECTION	74	Schematic	94
REAR LIFTING SWITCH CIRCUIT INSPECTION	75	WITH FRONT LEFT AND RIGHT HEATED SEATS	94
POWER SEAT SWITCH GROUND INSPECTION	76	WITH FRONT AND REAR HEATED SEATS	95
DOOR MIRROR REMOTE CONTROL SWITCH (CHANGEOVER SWITCH) CIRCUIT CHECK	77	Wiring Diagram–HSEAT–	96
DOOR MIRROR REMOTE CONTROL SWITCH (MIRROR SWITCH) CIRCUIT CHECK	79	WITH FRONT LEFT AND RIGHT HEATED SEATS	96
DOOR MIRROR REMOTE CONTROL SWITCH GROUND CIRCUIT CHECK	81	WITH FRONT AND REAR HEATED SEATS	99
STEERING WHEEL TELESCOPIC SWITCH CIRCUIT INSPECTION	82	FRONT SEAT	104
STEERING WHEEL TILT SWITCH CIRCUIT INSPECTION	84	Removal and Installation	104
SEAT MEMORY INDICATOR LAMP CIRCUIT INSPECTION	85	REMOVAL	107
UART COMMUNICATION LINE CIRCUIT INSPECTION	87	INSTALLATION	107
POWER SEAT	89	Disassembly and Assembly	107
		SEATBACK TRIM AND PAD	107
		REMOVAL OF SEATBACK ASSEMBLY	108
		INSTALLATION OF SEATBACK ASSEMBLY	108
		SEAT CUSHION TRIM AND PAD	108
		REAR SEAT	110
		Removal and Installation	110
		REMOVAL	110
		INSTALLATION	110
		Disassembly and Assembly	111

PRECAUTIONS

PRECAUTIONS

PFP:00001

Precautions for Supplemental Restraint System (SRS) “AIR BAG” and “SEAT BELT PRE-TENSIONER”

EIS001L1

The Supplemental Restraint System such as “AIR BAG” and “SEAT BELT PRE-TENSIONER”, used along with a front seat belt, helps to reduce the risk or severity of injury to the driver and front passenger for certain types of collision. This system includes seat belt switch inputs and dual stage front air bag modules. The SRS system uses the seat belt switches to determine the front air bag deployment, and may only deploy one front air bag, depending on the severity of a collision and whether the front occupants are belted or unbelted. Information necessary to service the system safely is included in the SRS and SB section of this Service Manual.

WARNING:

- To avoid rendering the SRS inoperative, which could increase the risk of personal injury or death in the event of a collision which would result in air bag inflation, all maintenance must be performed by an authorized NISSAN/INFINITI dealer.
- Improper maintenance, including incorrect removal and installation of the SRS, can lead to personal injury caused by unintentional activation of the system. For removal of Spiral Cable and Air Bag Module, see the SRS section.
- Do not use electrical test equipment on any circuit related to the SRS unless instructed to in this Service Manual. SRS wiring harnesses can be identified by yellow and/or orange harness connectors.

Precautions for Work

EIS001L2

- When removing or disassembling each component, be careful not to damage or deform it. If a component may be subject to interference, be sure to protect it with a shop cloth.
- When removing (disengaging) components with a screwdriver or similar tool, be sure to wrap the component with a shop cloth or vinyl tape to protect it.
- Protect the removed parts with a shop cloth and keep them.
- Replace a deformed or damaged clip.
- If a part is specified as a non-reusable part, always replace it with new one.
- Be sure to tighten bolts and nuts securely to the specified torque.
- After re-installation is completed, be sure to check that each part works normally.
- Follow the steps below to clean components.
 - Water soluble foul: Dip a soft cloth into lukewarm water, and wring the water out of the cloth to wipe the fouled area. Then rub with a soft and dry cloth.
 - Oily foul: Dip a soft cloth into lukewarm water with mild detergent (concentration: within 2 to 3%), and wipe the fouled area. Then dip a cloth into fresh water, and wring the water out of the cloth to wipe the detergent off. Then rub with a soft and dry cloth.
- Do not use organic solvent such as thinner, benzene, alcohol, or gasoline.
- For genuine leather seats, use a genuine leather seat cleaner.

PREPARATION

PREPARATION

PFP:00002

Special Service Tool

EIS001L3

The actual shapes of Kent-Moore tools may differ from those of special service tools illustrated here.

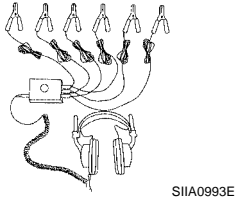
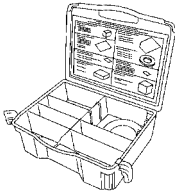
Tool number (Kent-Moore No.) Tool name	Description
<p>(J-39570) Chassis ear</p>  <p style="text-align: right; margin-right: 50px;">SIIA0993E</p>	<p>Locating the noise</p>
<p>(J-43980) NISSAN Squeak and Rattle Kit</p>  <p style="text-align: right; margin-right: 50px;">SIIA0994E</p>	<p>Repairing the cause of noise</p>

Commercial Service Tool

EIS001L4

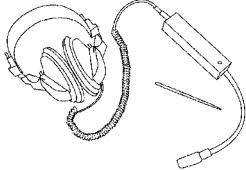
Tool name	Description
<p>(J-39565) Engine ear</p>  <p style="text-align: right; margin-right: 50px;">SIIA0995E</p>	<p>Locating the noise</p>

SQUEAK AND RATTLE TROUBLE DIAGNOSES

SQUEAK AND RATTLE TROUBLE DIAGNOSES

PF0:0000

Work Flow

EIS001L5

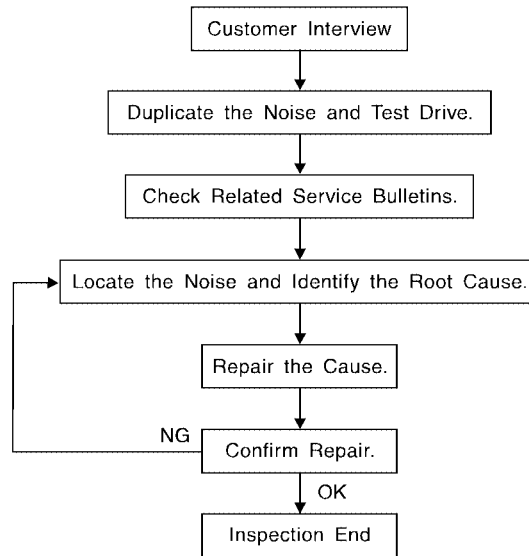

SBT842

CUSTOMER INTERVIEW

Interview the customer if possible, to determine the conditions that exist when the noise occurs. Use the Diagnostic Worksheet during the interview to document the facts and conditions when the noise occurs and any customer's comments; refer to [SE-9, "Diagnostic Worksheet"](#). This information is necessary to duplicate the conditions that exist when the noise occurs.

- The customer may not be able to provide a detailed description or the location of the noise. Attempt to obtain all the facts and conditions that exist when the noise occurs (or does not occur).
- If there is more than one noise in the vehicle, be sure to diagnose and repair the noise that the customer is concerned about. This can be accomplished by test driving the vehicle with the customer.
- After identifying the type of noise, isolate the noise in terms of its characteristics. The noise characteristics are provided so the customer, service adviser and technician are all speaking the same language when defining the noise.
- Squeak —(Like tennis shoes on a clean floor)
Squeak characteristics include the light contact/fast movement/brought on by road conditions/hard surfaces = higher pitch noise/softer surfaces = lower pitch noises/edge to surface = chirping
- Creak—(Like walking on an old wooden floor)
Creak characteristics include firm contact/slow movement/twisting with a rotational movement/pitch dependent on materials/often brought on by activity.
- Rattle—(Like shaking a baby rattle)
Rattle characteristics include the fast repeated contact/vibration or similar movement/loose parts/missing clip or fastener/incorrect clearance.
- Knock —(Like a knock on a door)
Knock characteristics include hollow sounding/sometimes repeating/often brought on by driver action.
- Tick—(Like a clock second hand)
Tick characteristics include gentle contacting of light materials/loose components/can be caused by driver action or road conditions.
- Thump—(Heavy, muffled knock noise)
Thump characteristics include softer knock/dead sound often brought on by activity.
- Buzz—(Like a bumble bee)
Buzz characteristics include high frequency rattle/firm contact.
- Often the degree of acceptable noise level will vary depending upon the person. A noise that you may judge as acceptable may be very irritating to the customer.
- Weather conditions, especially humidity and temperature, may have a great affect on noise level.

SQUEAK AND RATTLE TROUBLE DIAGNOSES

DUPLICATE THE NOISE AND TEST DRIVE

If possible, drive the vehicle with the customer until the noise is duplicated. Note any additional information on the Diagnostic Worksheet regarding the conditions or location of the noise. This information can be used to duplicate the same conditions when you confirm the repair.

If the noise can be duplicated easily during the test drive, to help identify the source of the noise, try to duplicate the noise with the vehicle stopped by doing one or all of the following:

- 1) Close a door.
 - 2) Tap or push/pull around the area where the noise appears to be coming from.
 - 3) Rev the engine.
 - 4) Use a floor jack to recreate vehicle "twist".
 - 5) At idle, apply engine load (electrical load, half-clutch on M/T model, drive position on A/T model).
 - 6) Raise the vehicle on a hoist and hit a tire with a rubber hammer.
- Drive the vehicle and attempt to duplicate the conditions the customer states exist when the noise occurs.
 - If it is difficult to duplicate the noise, drive the vehicle slowly on an undulating or rough road to stress the vehicle body.

CHECK RELATED SERVICE BULLETINS

After verifying the customer concern or symptom, check ASIST for Technical Service Bulletins (TSBs) related to that concern or symptom.

If a TSB relates to the symptom, follow the procedure to repair the noise.

LOCATE THE NOISE AND IDENTIFY THE ROOT CAUSE

1. Narrow down the noise to a general area. To help pinpoint the source of the noise, use a listening tool (Chassis Ear: J-39570, Engine Ear: J-39565 and mechanic's stethoscope).
2. Narrow down the noise to a more specific area and identify the cause of the noise by:
 - removing the components in the area that you suspect the noise is coming from. Do not use too much force when removing clips and fasteners, otherwise clips and fasteners can be broken or lost during the repair, resulting in the creation of new noise.
 - tapping or pushing/pulling the component that you suspect is causing the noise. Do not tap or push/pull the component with excessive force, otherwise the noise will be eliminated only temporarily.
 - feeling for a vibration with your hand by touching the component(s) that you suspect is (are) causing the noise.
 - placing a piece of paper between components that you suspect are causing the noise.
 - looking for loose components and contact marks.
Refer to [SE-7, "Generic Squeak and Rattle Troubleshooting"](#).

REPAIR THE CAUSE

- If the cause is a loose component, tighten the component securely.
- If the cause is insufficient clearance between components:
 - separate components by repositioning or loosening and retightening the component, if possible.
 - insulate components with a suitable insulator such as urethane pads, foam blocks, felt cloth tape or urethane tape. A NISSAN Squeak and Rattle Kit (J-43980) is available through your authorized Nissan Parts Department.

CAUTION:

Do not use excessive force as many components are constructed of plastic and may be damaged.

Always check with the Parts Department for the latest parts information.

The following materials are contained in the NISSAN Squeak and Rattle Kit (J-43980). Each item can be ordered separately as needed.

URETHANE PADS [1.5 mm (0.059 in) thick]

Insulates connectors, harness, etc.

76268-9E005: 100×135 mm (3.94×5.31 in)/76884-71L01: 60×85 mm (2.36×3.35 in)/76884-71L02: 15×25mm(0.59×0.98 in)

INSULATOR (Foam blocks)

Insulates components from contact. Can be used to fill space behind a panel.

73982-9E000: 45 mm (1.77 in) thick, 50×50 mm (1.97×1.97 in)/73982-50Y00: 10 mm (0.39 in) thick, 50×50 mm (1.97×1.97 in)

INSULATOR (Light foam block)

SQUEAK AND RATTLE TROUBLE DIAGNOSES

80845-71L00: 30 mm (1.18 in) thick, 30×50 mm (1.18×1.97 in)

FELT CLOTH TAPE

Used to insulate where movement does not occur. Ideal for instrument panel applications.

68370-4B000: 15×25 mm (0.59×0.98 in) pad/68239-13E00: 5 mm (0.20 in) wide tape roll. The following materials, not found in the kit can also be used to repair squeaks and rattles.

UHMW (TEFLON) TAPE

Insulates where slight movement is present. Ideal for instrument panel applications.

SILICONE GREASE

Used in place of UHMW tape that will be visible or not fit.

Note: Will only last a few months.

SILICONE SPRAY

Use when grease cannot be applied.

DUCT TAPE

Use to eliminate movement.

CONFIRM THE REPAIR

Confirm that the cause of a noise is repaired by test driving the vehicle. Operate the vehicle under the same conditions as when the noise originally occurred. Refer to the notes on the Diagnostic Worksheet.

Generic Squeak and Rattle Troubleshooting

EIS001L6

Refer to Table of Contents for specific component removal and installation information.

INSTRUMENT PANEL

Most incidents are caused by contact and movement between:

1. The cluster lid A and instrument panel
2. Acrylic lens and combination meter housing
3. Instrument panel to front pillar garnish
4. Instrument panel to windshield
5. Instrument panel mounting pins
6. Wiring harnesses behind the combination meter
7. A/C defroster duct and duct joint

These incidents can usually be located by tapping or moving the components to duplicate the noise or by pressing on the components while driving to stop the noise. Most of these incidents can be repaired by applying felt cloth tape or silicone spray (in hard to reach areas). Urethane pads can be used to insulate wiring harness.

CAUTION:

Do not use silicone spray to isolate a squeak or rattle. If you saturate the area with silicone, you will not be able to recheck the repair.

CENTER CONSOLE

Components to pay attention to include:

1. Shifter assembly cover to finisher
2. A/C control unit and cluster lid C
3. Wiring harnesses behind audio and A/C control unit

The instrument panel repair and isolation procedures also apply to the center console.

DOORS

Pay attention to the:

1. Finisher and inner panel making a slapping noise
2. Inside handle escutcheon to door finisher
3. Wiring harnesses tapping
4. Door striker out of alignment causing a popping noise on starts and stops

Tapping or moving the components or pressing on them while driving to duplicate the conditions can isolate many of these incidents. You can usually insulate the areas with felt cloth tape or insulator foam blocks from the NISSAN Squeak and Rattle Kit (J-43980) to repair the noise.

SQUEAK AND RATTLE TROUBLE DIAGNOSES

TRUNK

Trunk noises are often caused by a loose jack or loose items put into the trunk by the owner. In addition look for:

1. Trunk lid bumpers out of adjustment
2. Trunk lid striker out of adjustment
3. The trunk lid torsion bars knocking together
4. A loose license plate or bracket

Most of these incidents can be repaired by adjusting, securing or insulating the item(s) or component(s) causing the noise.

SUNROOF/HEADLINING

Noises in the sunroof/headlining area can often be traced to one of the following:

1. Sunroof lid, rail, linkage or seals making a rattle or light knocking noise
2. Sunvisor shaft shaking in the holder
3. Front or rear windshield touching headlining and squeaking

Again, pressing on the components to stop the noise while duplicating the conditions can isolate most of these incidents. Repairs usually consist of insulating with felt cloth tape.

SEATS

When isolating seat noise it is important to note the position the seat is in and the load placed on the seat when the noise is present. These conditions should be duplicated when verifying and isolating the cause of the noise.

Cause of seat noise include:

1. Headrest rods and holder
2. A squeak between the seat pad cushion and frame
3. The rear seatback lock and bracket

These noises can be isolated by moving or pressing on the suspected components while duplicating the conditions under which the noise occurs. Most of these incidents can be repaired by repositioning the component or applying urethane tape to the contact area.

UNDERHOOD

Some interior noise may be caused by components under the hood or on the engine wall. The noise is then transmitted into the passenger compartment.

Causes of transmitted underhood noise include:

1. Any component mounted to the engine wall
2. Components that pass through the engine wall
3. Engine wall mounts and connectors
4. Loose radiator mounting pins
5. Hood bumpers out of adjustment
6. Hood striker out of adjustment

These noise can be difficult to isolate since they cannot be reached from the interior of the vehicle. The best method is to secure, move or insulate one component at a time and test drive the vehicle. Also, engine RPM or load can be changed to isolate the noise. Repairs can usually be made by moving, adjusting securing, or insulating the component causing the noise.

SQUEAK AND RATTLE TROUBLE DIAGNOSES

Diagnostic Worksheet

EIS001L7



SQUEAK & RATTLE DIAGNOSTIC WORKSHEET

Dear Nissan Customer:

We are concerned about your satisfaction with your Nissan vehicle. Repairing a squeak or rattle sometimes can be very difficult. To help us fix your Nissan right the first time, please take a moment to note the area of the vehicle where the squeak or rattle occurs and under what conditions. You may be asked to take a test drive with a service advisor or technician to ensure we confirm the noise you are hearing.

I. WHERE DOES THE NOISE COME FROM? (circle the area of the vehicle)

The illustrations are for reference only, and may not reflect the actual configuration of your vehicle.

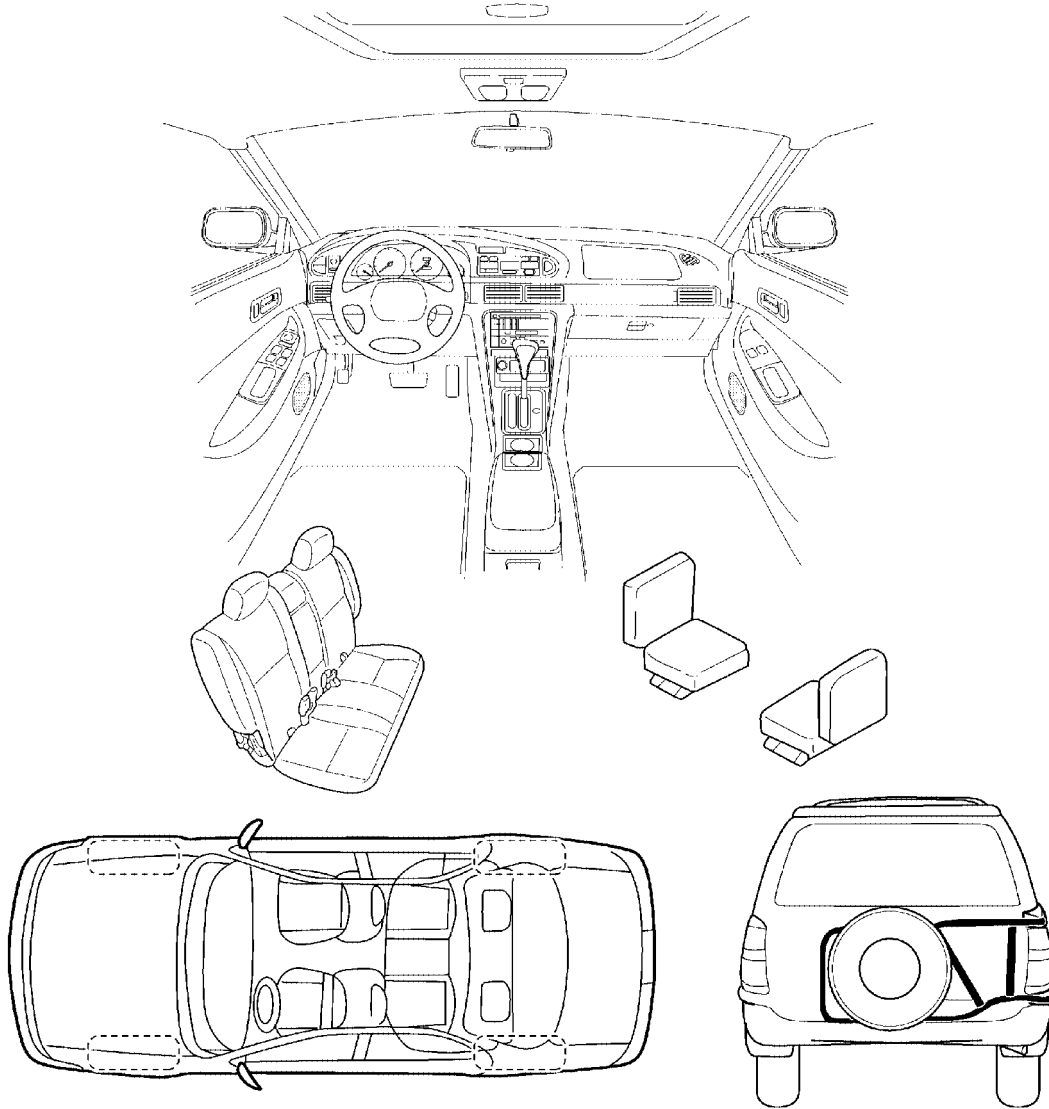

Continue to the back of the worksheet and briefly describe the location of the noise or rattle. In addition, please indicate the conditions which are present when the noise occurs.

SBT843

A
B
C
D
E
F
G
H
SE
J
K
L
M

SQUEAK AND RATTLE TROUBLE DIAGNOSES

SQUEAK & RATTLE DIAGNOSTIC WORKSHEET- page 2

Briefly describe the location where the noise occurs:

II. WHEN DOES IT OCCUR? (check the boxes that apply)

- | | |
|--|---|
| <input type="checkbox"/> anytime | <input type="checkbox"/> after sitting out in the sun |
| <input type="checkbox"/> 1 st time in the morning | <input type="checkbox"/> when it is raining or wet |
| <input type="checkbox"/> only when it is cold outside | <input type="checkbox"/> dry or dusty conditions |
| <input type="checkbox"/> only when it is hot outside | <input type="checkbox"/> other: _____ |

III. WHEN DRIVING:

- through driveways
- over rough roads
- over speed bumps
- only at about ____ mph
- on acceleration
- coming to a stop
- on turns : left, right or either (circle)
- with passengers or cargo
- other: _____
- after driving ____ miles or ____ minutes

IV. WHAT TYPE OF NOISE?

- squeak (like tennis shoes on a clean floor)
- creak (like walking on an old wooden floor)
- rattle (like shaking a baby rattle)
- knock (like a knock on a door)
- tick (like a clock second hand)
- thump (heavy, muffled knock noise)
- buzz (like a bumble bee)

TO BE COMPLETED BY DEALERSHIP PERSONNEL

Test Drive Notes:

	YES	NO	Initials of person performing
Vehicle test driven with customer	<input type="checkbox"/>	<input type="checkbox"/>	_____
- Noise verified on test drive	<input type="checkbox"/>	<input type="checkbox"/>	_____
- Noise source located and repaired	<input type="checkbox"/>	<input type="checkbox"/>	_____
- Follow up test drive performed to confirm repair	<input type="checkbox"/>	<input type="checkbox"/>	_____

VIN: _____ Customer Name: _____

W.O. #: _____ Date: _____

SBT844

This form must be attached to Work Order

AUTOMATIC DRIVE POSITIONER

PFP:28491

EIS001NR

AUTOMATIC DRIVE POSITIONER

System Description OPERATIVE CONDITION

The drive position can be set in 2 ways, manually and automatically.

Manual Operation

The driving position [seat position, steering wheel position and door mirror position] can be adjusted with the power seat switch or ADP steering switch or door mirror remote control switch.

NOTE:

- The door mirrors can be manually operated with the ignition switch turned ACC or ON.
- If detection switch error is detected, manual adjustable pedal operation cannot be performed when ignition switch turns ON.

Automatic Operation

Function		Description
Memory operation		The seat, steering wheel and door mirror move to the stored driving position by pushing memory switch (1 or 2).
Entry/Exiting function	Exiting operation	At exit, the seat moves backward and the steering wheel raises. (Exiting position)
	Entry operation	At entry, the seat and steering wheel entry from the exiting position to the previous driving position. before the exiting operation.
Key fob interlock operation		Perform memory operation, exiting operation and entry operation by pressing key fob unlock button.

NOTE:

- Disconnecting the battery erases the stored memory.
- After connecting the battery, insert the key into the ignition cylinder and turn the driver door switch ON (open)→OFF (close)→ON (open), the Entry/ Exiting operation becomes possible.
- After exiting operation is carried out, entry operation can be operated.

Auto operation temporary stop conditions.	When ignition switch turns to START during memory switch operation and entry operation, memory switch operation and entry operation is stopped.
Auto operation stop conditions.	<ul style="list-style-type: none"> ● When the vehicle speed becomes 7 km/h (4 MPH) or higher. (memory switch operation and entry operation) ● When the setting switch, memory switch 1, or 2 are pressed. ● When A/T selector lever is in any position other than P (A/T models). ● When the parking brake switch is in the OFF position (M/T models) ● When the door mirror remote control switch is operated (when ignition switch turned to ON). ● When power seat switch turned ON. ● When door mirror operates. ● When driver seat sliding Entry/Exiting setting is OFF (entry/exiting operation).

NOTE:

During automatic operation, if the ignition switch is turned ON→START, the automatic operation is suspended. When the ignition switch enters to ON, it resumes.

SYSTEM DESCRIPTION

- The system automatically moves the driver seat and steering wheel to facilitate entry/exit to/from the vehicle. The automatic driver positioner control unit can also store the optimum driving positions (driver seat, steering wheel position and door mirror position) for 2 people. If the driver is changes, one-touch operation allows changing to the other driving position.
- The settings (ON/OFF) of the automatic sliding seat (Entry/Exiting operation) at entry/exit can be changed as desired, using the display unit in the center of the instrument panel.

Fail- Safe Mode

When the ignition switch is in the ON position, if any of the parts (indicated in the following chart) move more than the specified amount within a period "T1" when no "ON" input is sent from any of the switches (indicated in the following chart), or an output from the automatic drive positioner is not produced, an output malfunction

AUTOMATIC DRIVE POSITIONER

is sensed. Motor operation will be suspended automatically, and all automatic operations will be ineffective. (In this case, the motor will not operate manually).

OPERATED PORTION	T1
Seat sliding	Approx. 2.5 sec.
Seat reclining	Same as above
Seat lifting (Front)	Same as above
Seat lifting (Rear)	Same as above
Steering wheel	Same as above

Cancel of Fail-safe Mode

- The mode is cancelled when the selector lever is shifted to P position from any other position.

AUTOMATIC DRIVE POSITIONER

Memory Storing and Key Fob Interlock Storing

- Store the 2 driving positions and shifts to the stored driving position with the memory switch.
- Key fob interlock function is set simultaneously with setting driving position memory. It can set driving position to memory position.

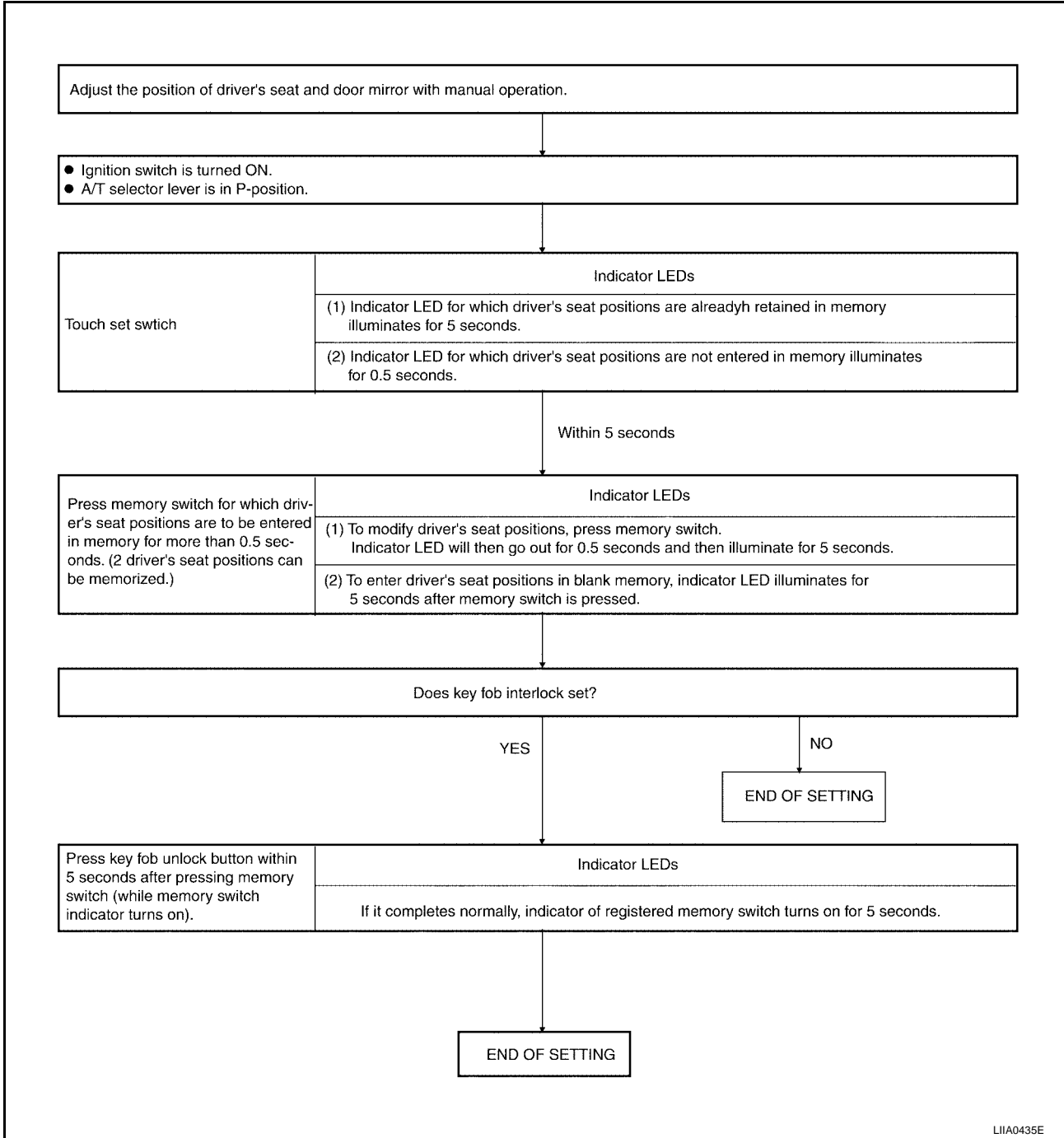

NOTE:

- If another key fob inter lock function setting is performed by same key, newly registered setting is valid.
- If new memory string is performed to memory switch that already set key fob interlock function, key fob interlock function setting is reset.
- If key fob does not set previously, key fob interlock function cannot set.

AUTOMATIC DRIVE POSITIONER

Memory Operation

Selecting the memorized position.

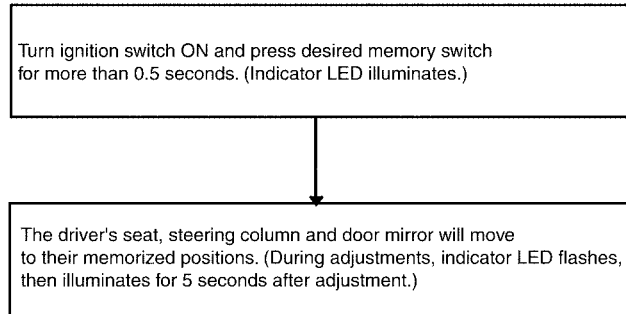

LIA0436E

NOTE:

The driver's seat position and steering adjustment functions (see the following table) operate simultaneously in the order of priority.

Priority	Function	Priority	Function
1	Seat sliding, (door mirror LH/RH)*	4	Seat lifter-FR
2	Steering wheel	5	Seat lifter-RR
3	Seat reclining		

*: In conjunction with sliding the seat, the door mirrors are positioned.

Entry Operation

When the seat are on the exiting positions, the following operation moves the seat and the steering wheel to the previous position before the exiting operation.

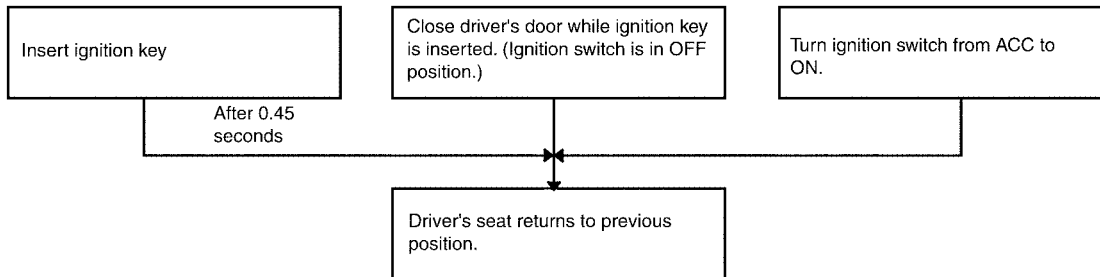

LIA0437E

Exiting Operation

At exit, the seat are automatically moved to the exiting position.

- Seat: moves backward

AUTOMATIC DRIVE POSITIONER

- Steering wheel: raises.

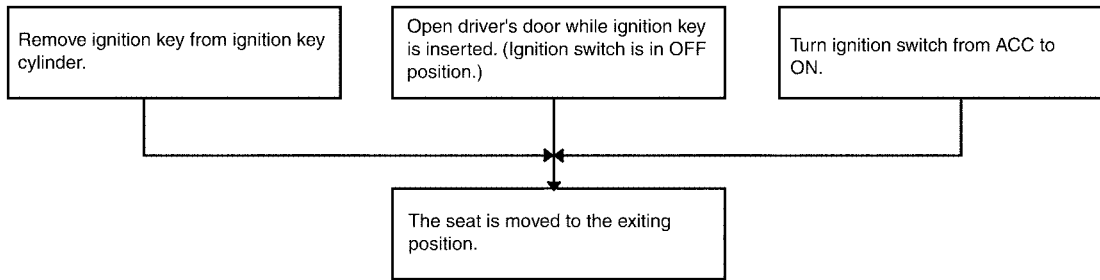

LIIA0438E

Key Fob Interlock Operation

- Perform memory operation, exiting operation and entry operation by pressing key fob unlock button.

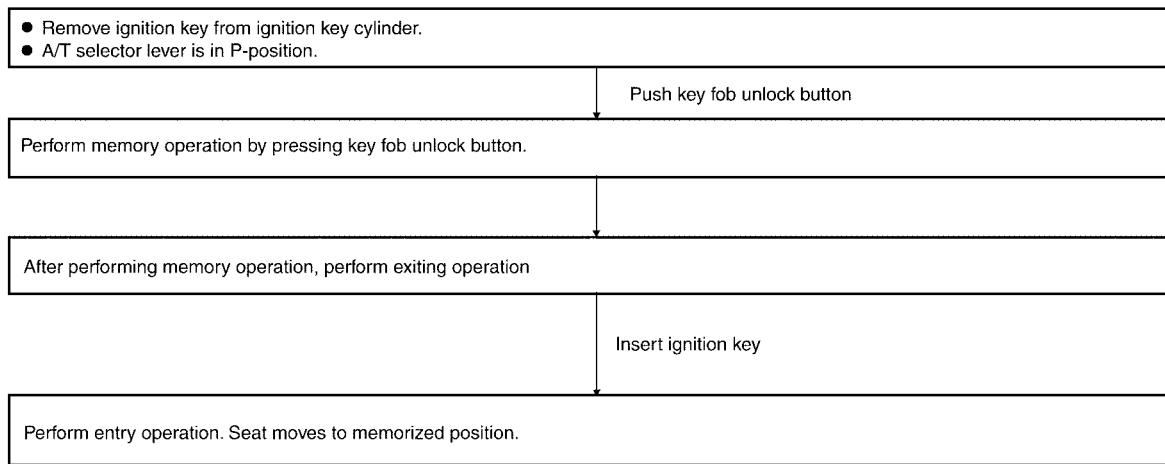

LIIA0439E

NOTE:

- If Entry/Exiting operation is cancelled, perform memory operation only.
- If ignition switch turns ON in the middle of memory operation, do not perform exiting operation after memory operation.
- If ignition switch turns ON in the middle of exiting operation, shift into entry operation at that time.

AUTOMATIC DRIVE POSITIONER

EIS001NS

Component Parts and Harness Connector Location

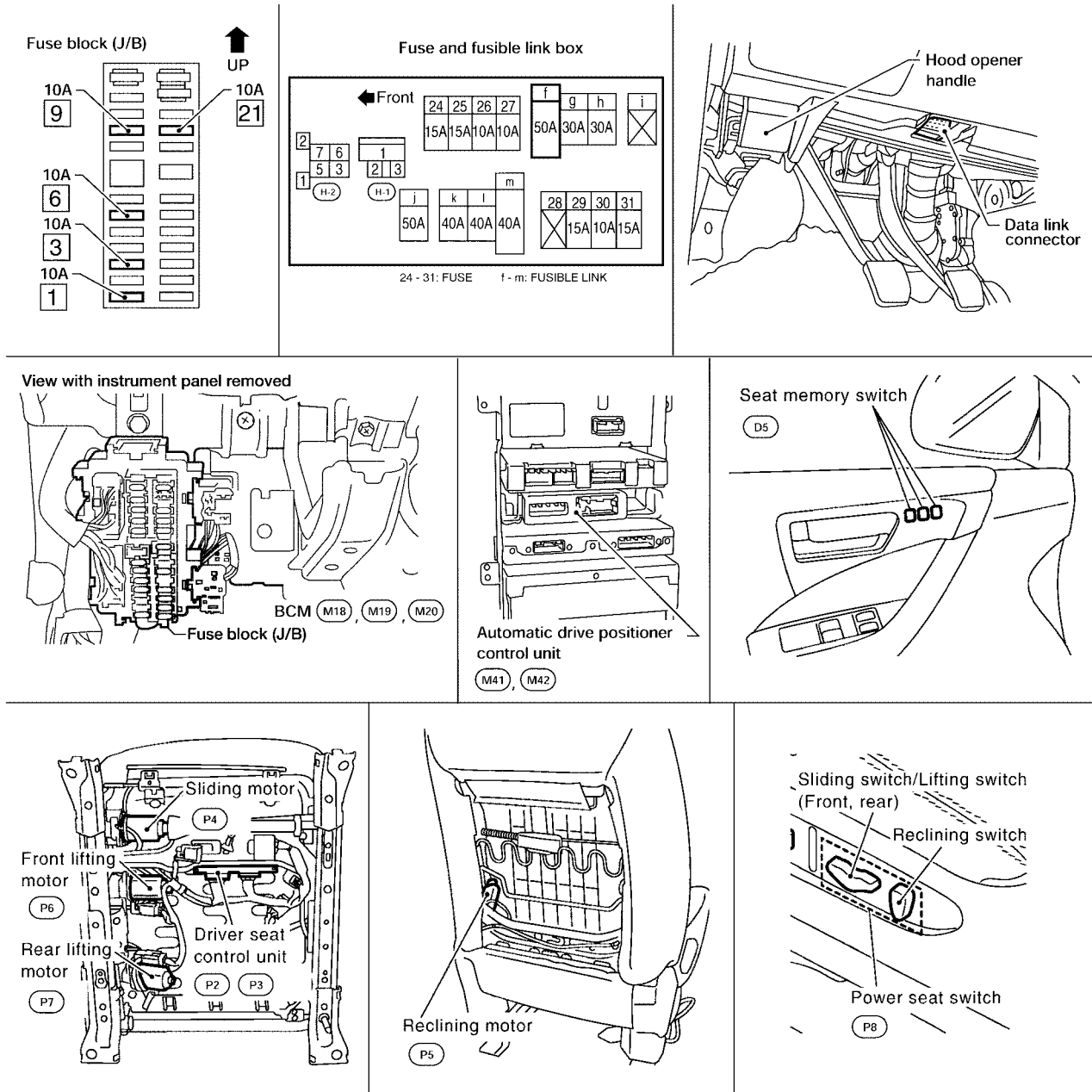

LIA0434E

AUTOMATIC DRIVE POSITIONER

Schematic

EIS001NT

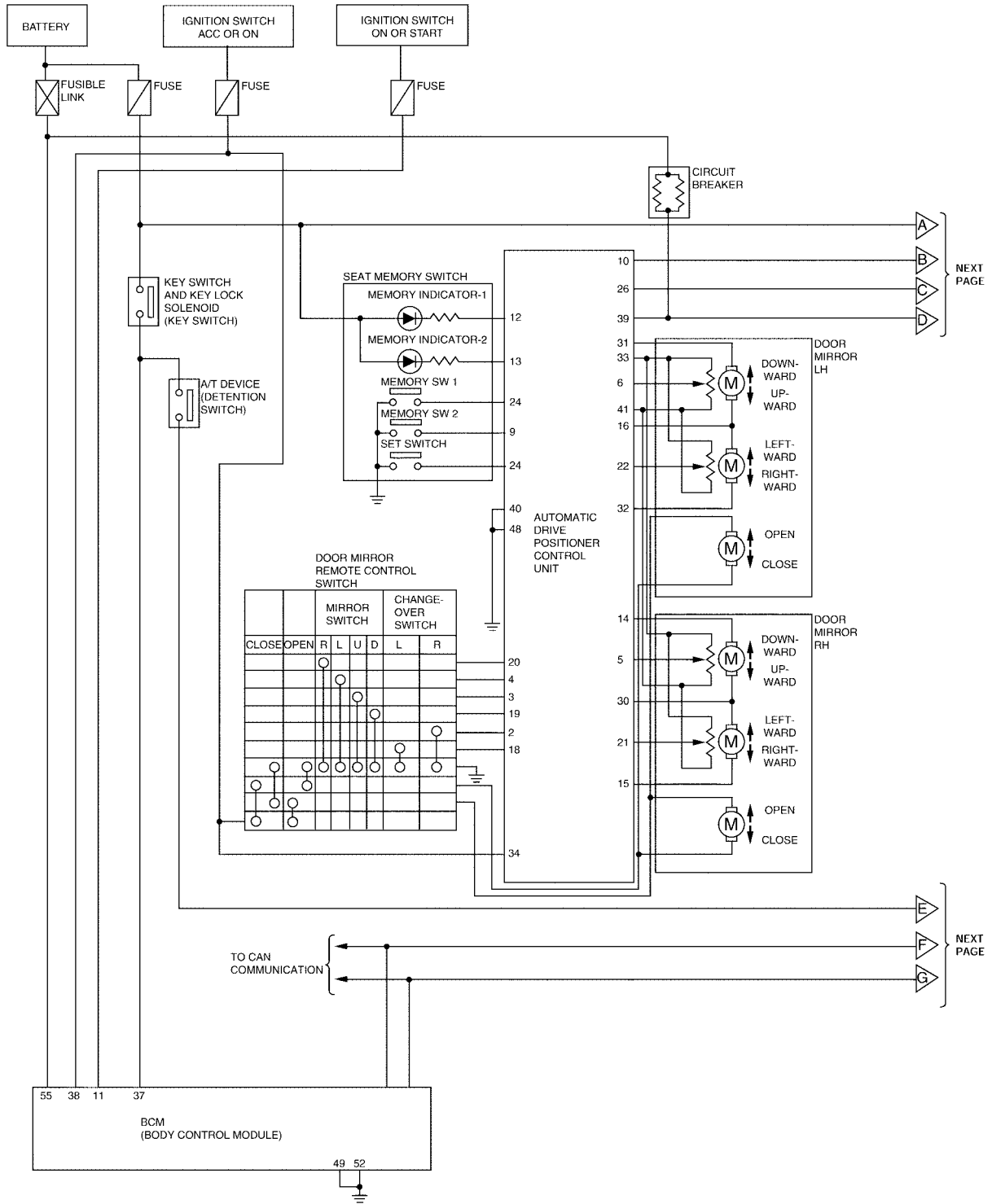

A
B
C
D
E
F
G
H
SE
J
K
L
M

SE

LIWA0116E

AUTOMATIC DRIVE POSITIONER

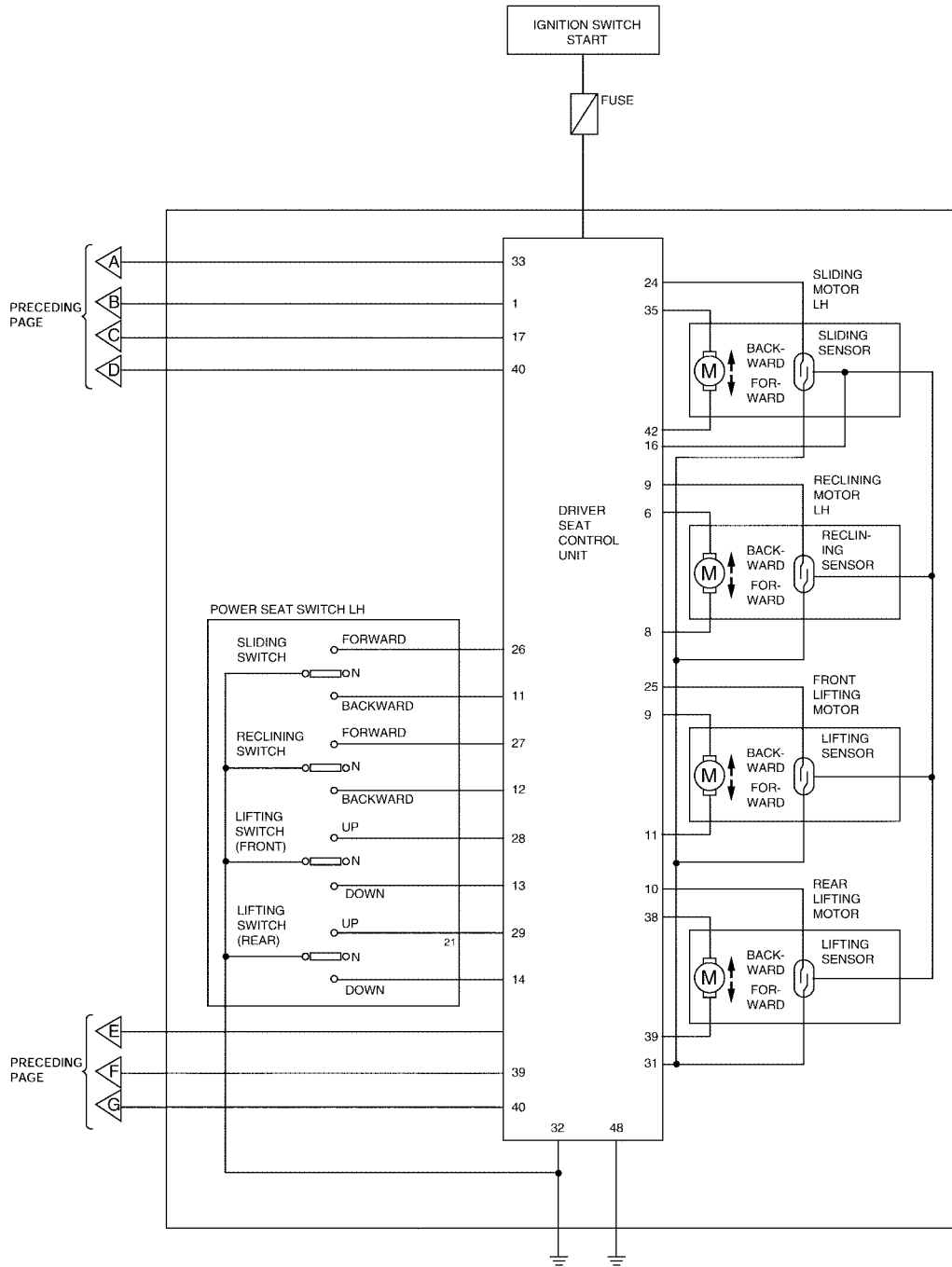

LIWA0117E

AUTOMATIC DRIVE POSITIONER

EIS001NU

Wiring Diagram—AUT/DP—

SE-AUT/DP-01

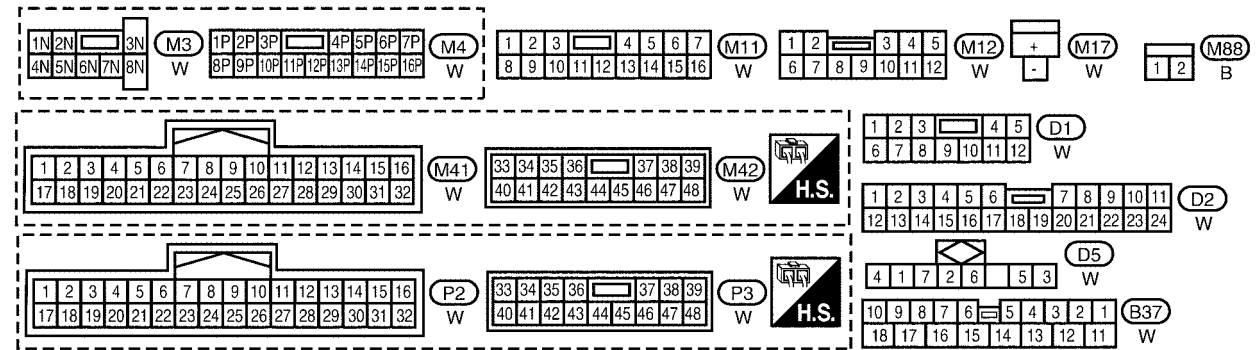
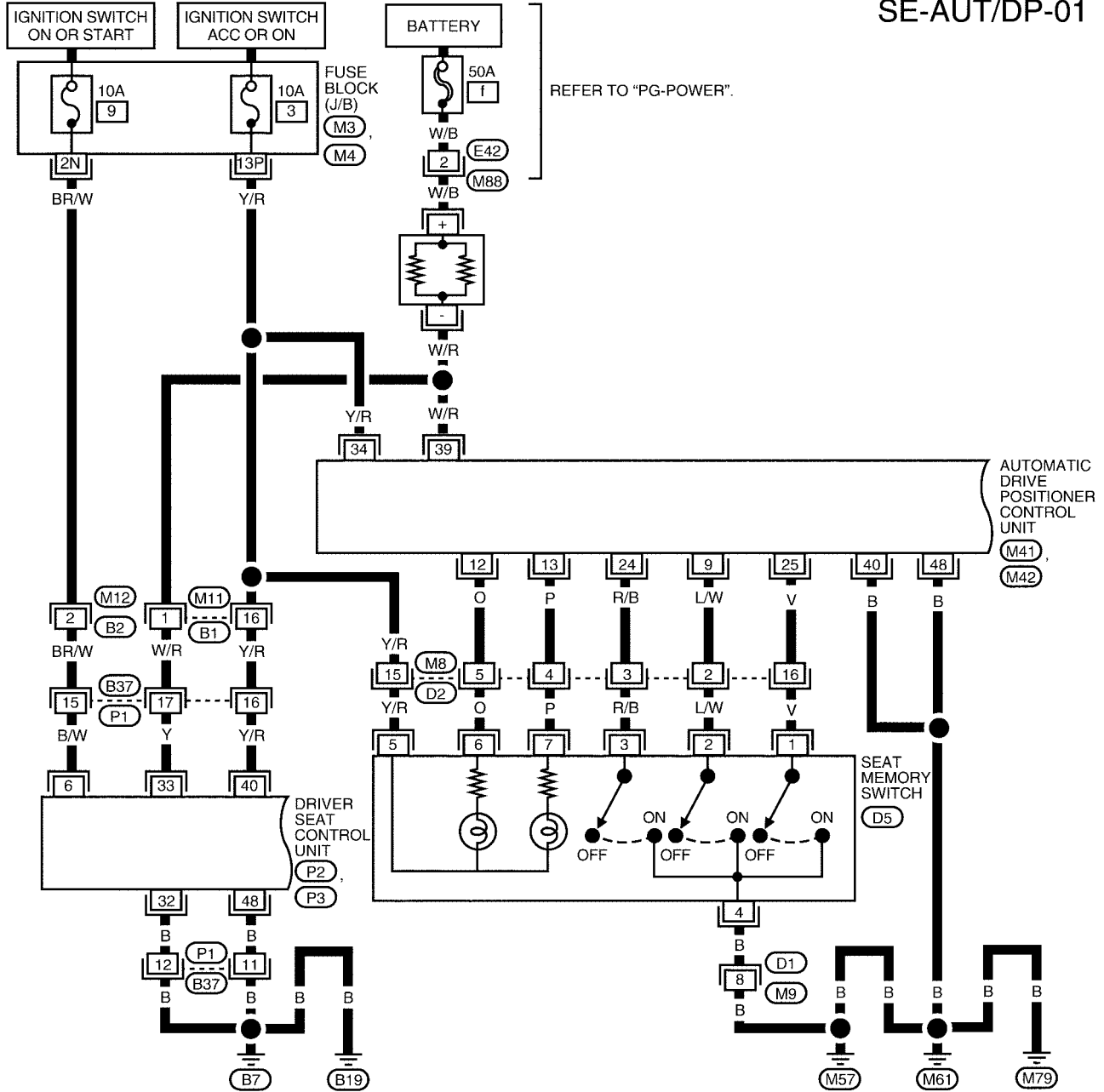

A
B
C
D
E
F
G
H
SE
J
K
L
M

AUTOMATIC DRIVE POSITIONER

SE-AUT/DP-02

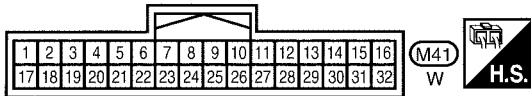
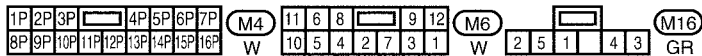
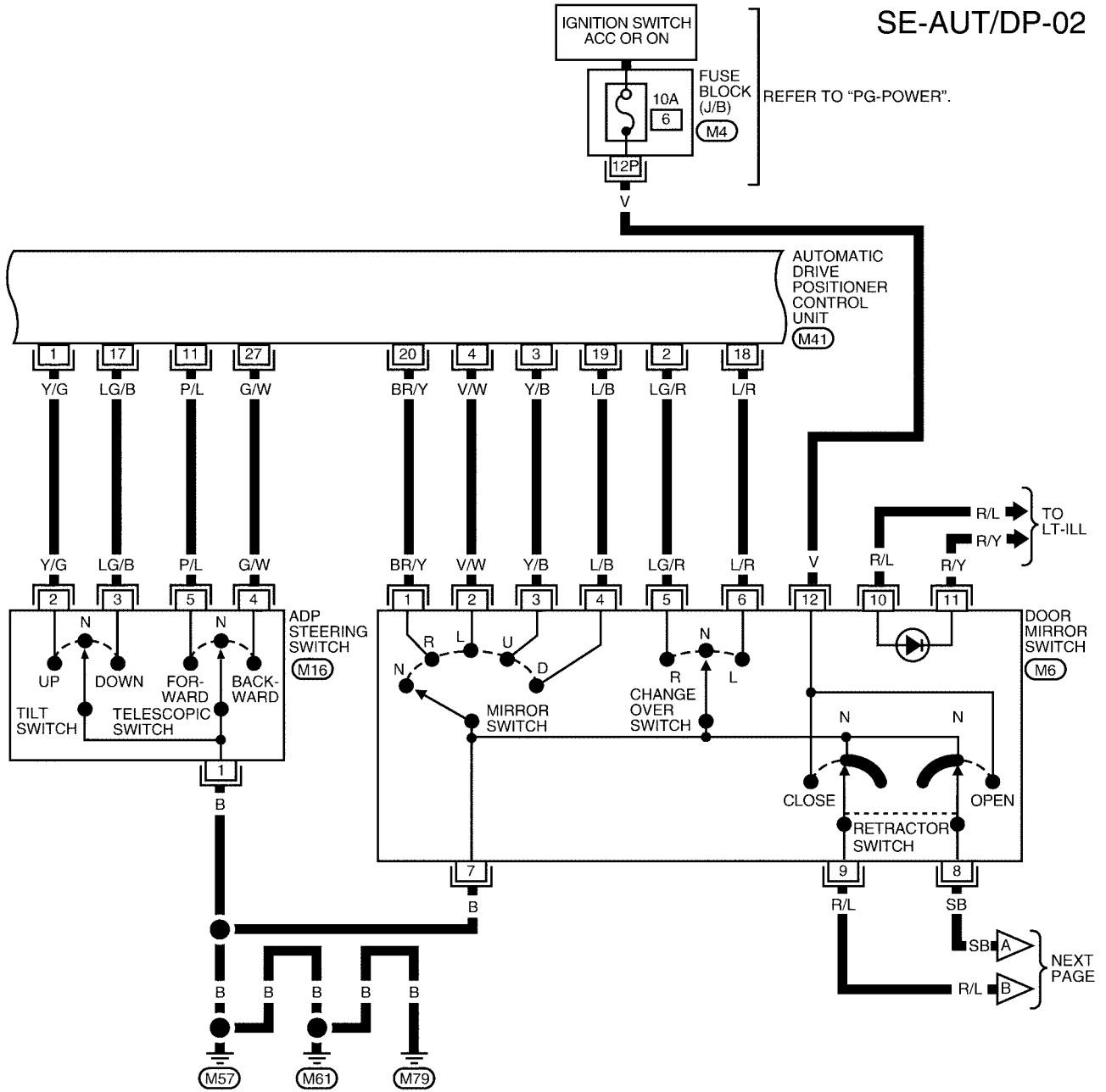

AUTOMATIC DRIVE POSITIONER

SE-AUT/DP-03

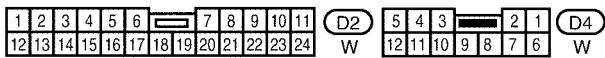
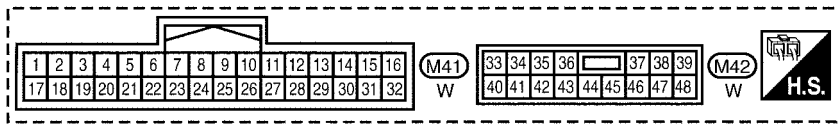
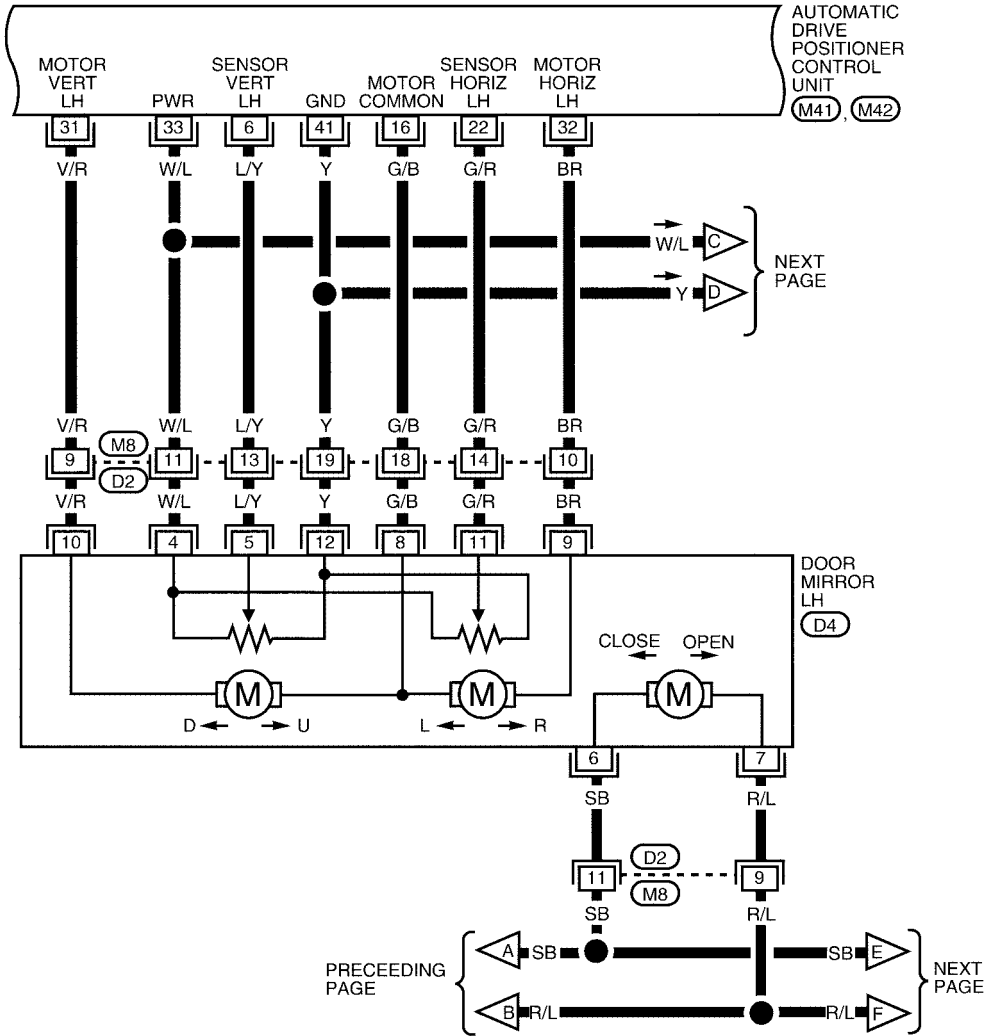

LIWA0077E

AUTOMATIC DRIVE POSITIONER

SE-AUT/DP-04

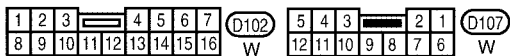
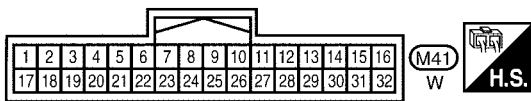
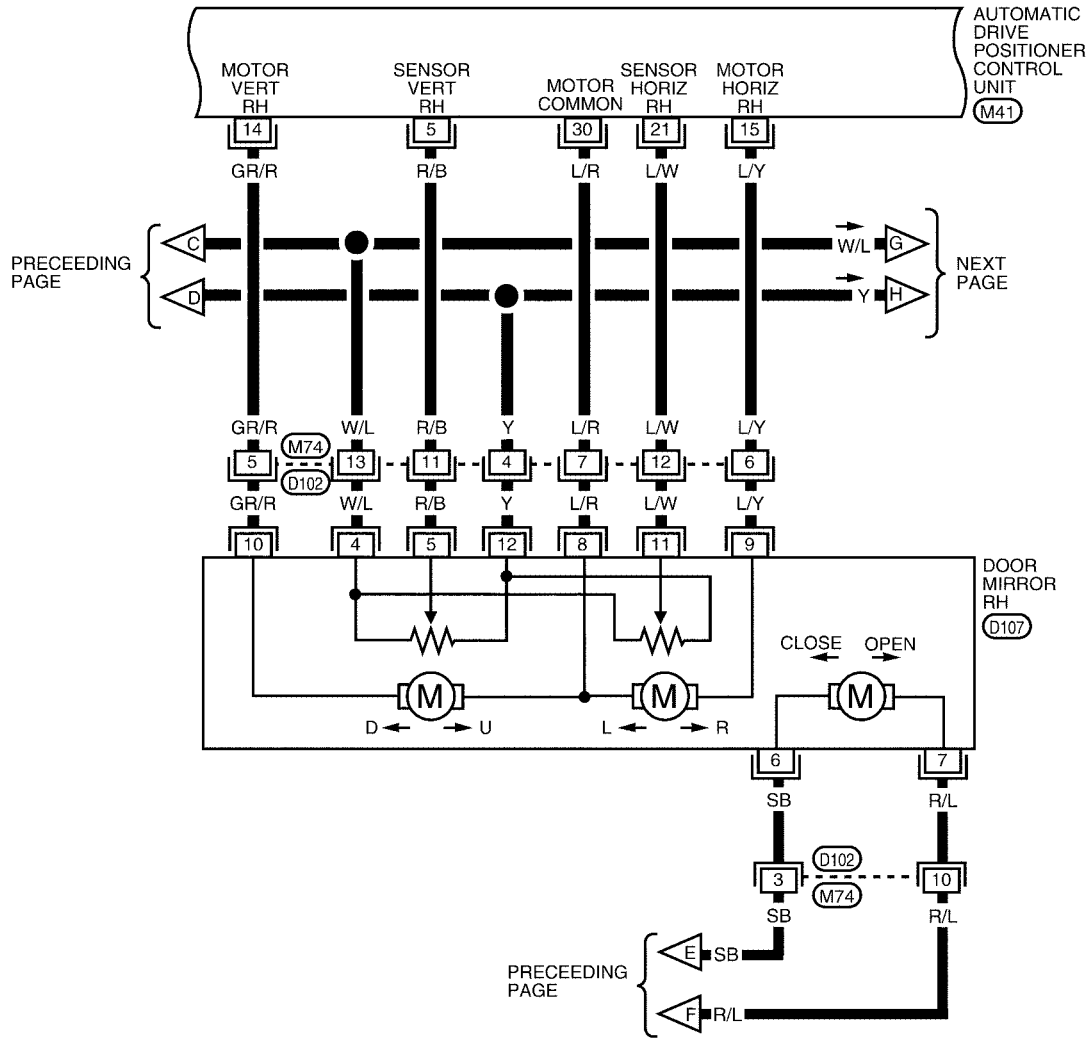

LIWA0078E

AUTOMATIC DRIVE POSITIONER

SE-AUT/DP-05

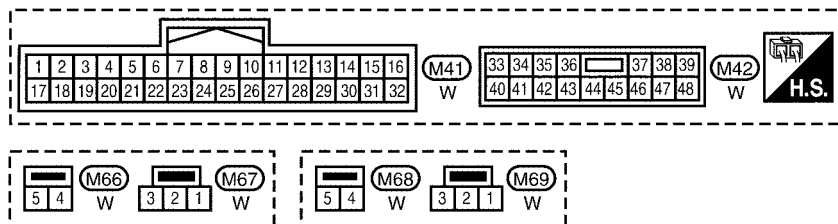
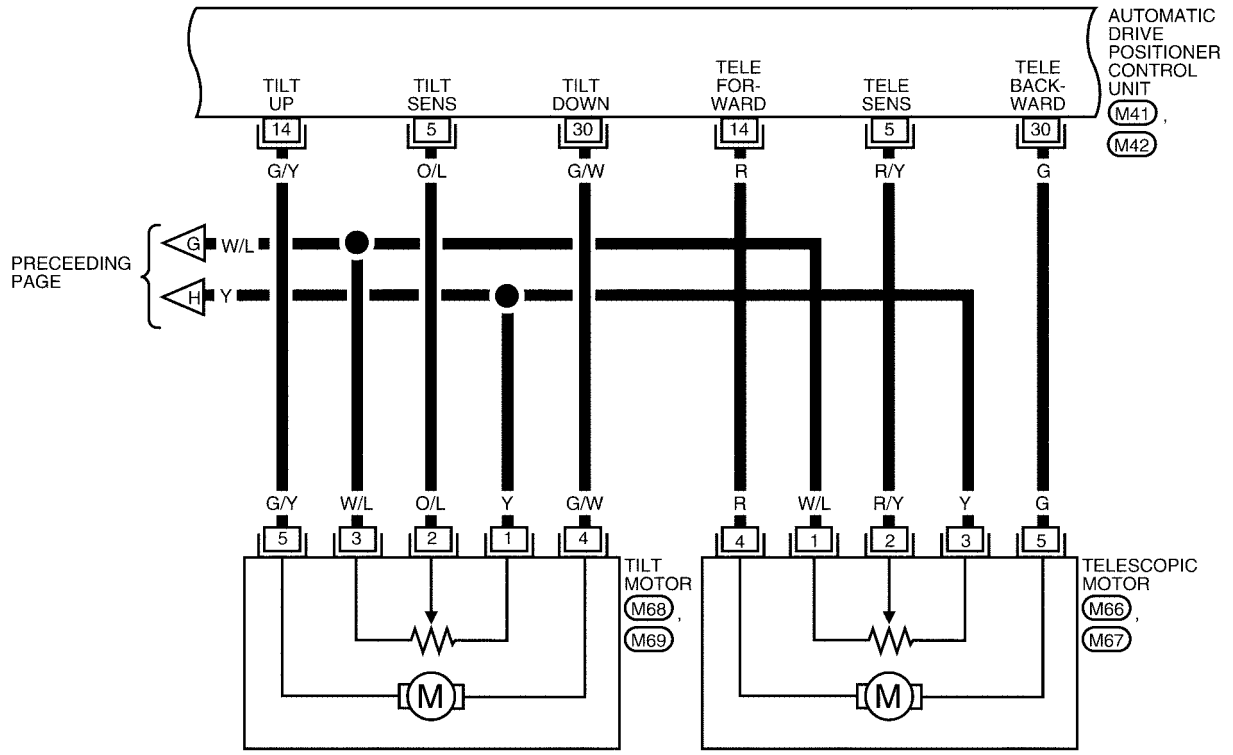

LIWA0079E

AUTOMATIC DRIVE POSITIONER

SE-AUT/DP-06

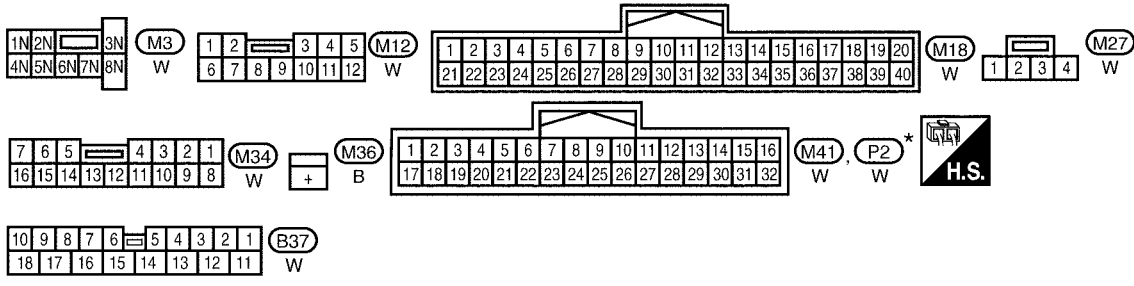
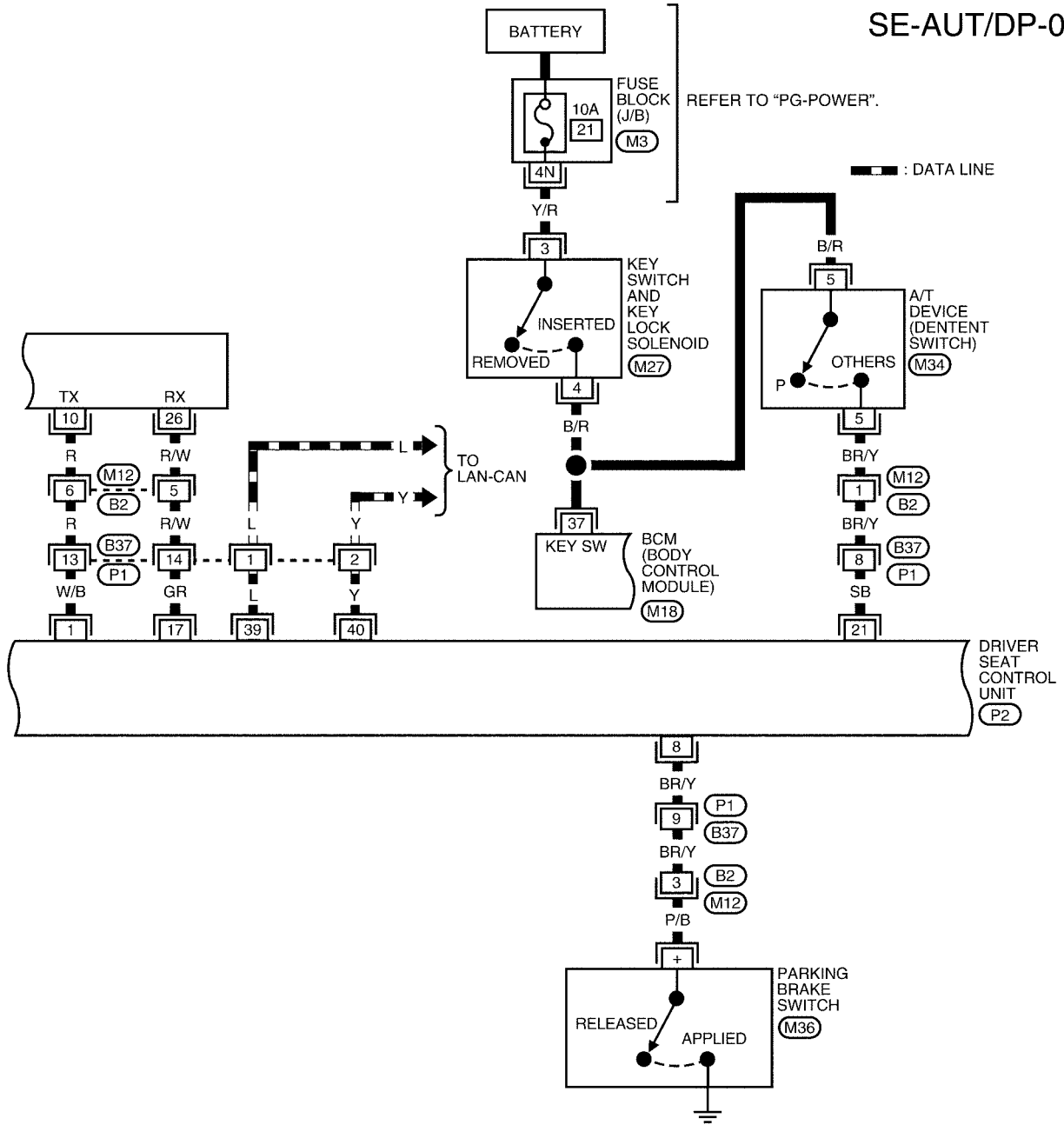

LIIWA0080E

AUTOMATIC DRIVE POSITIONER

SE-AUT/DP-07

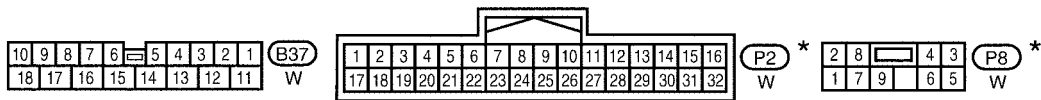
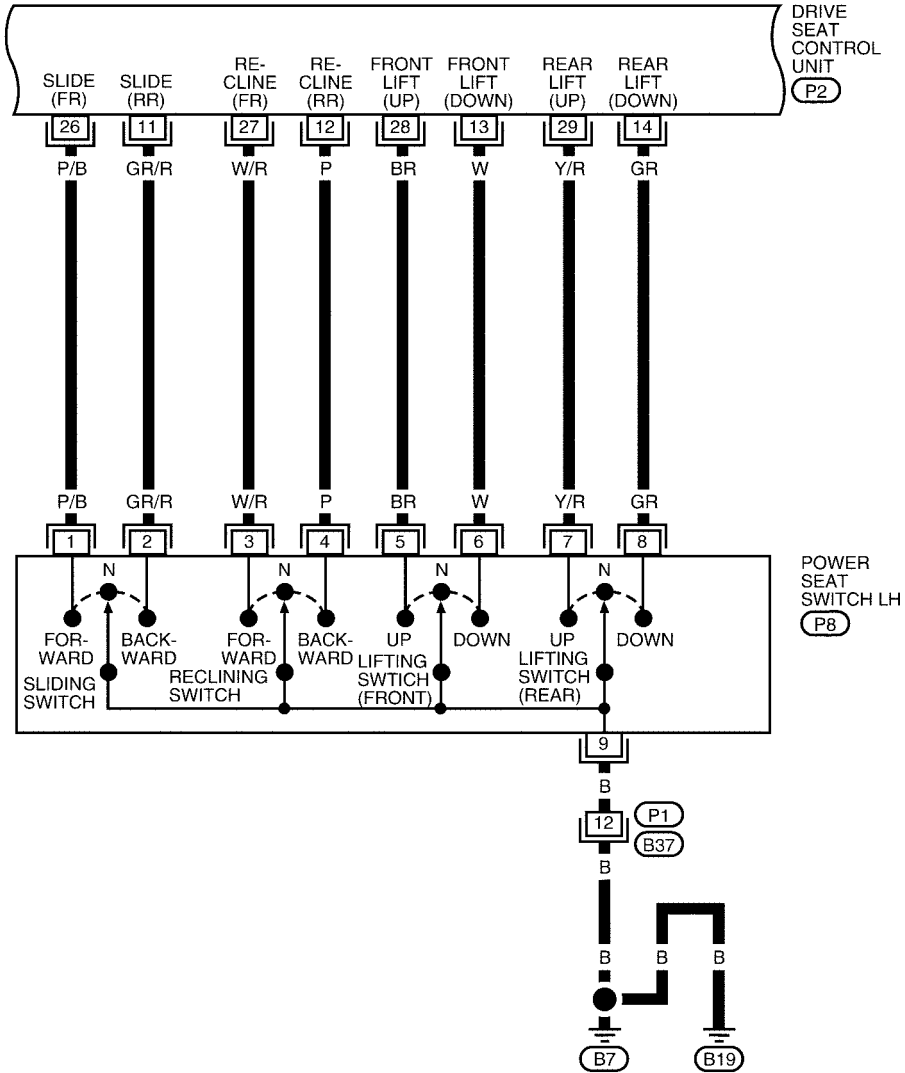

* : THIS CONNECTOR IS NOT SHOWN IN "HARNESS LAYOUT" OF PG SECTION.

LIWA0081E

AUTOMATIC DRIVE POSITIONER

SE-AUT/DP-08

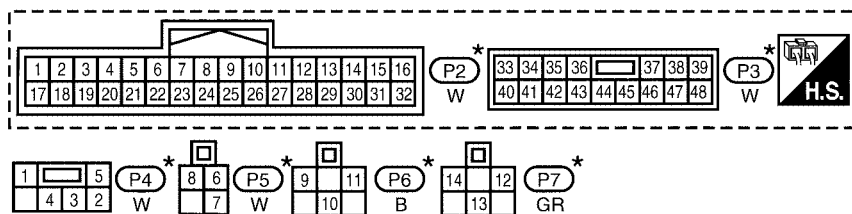
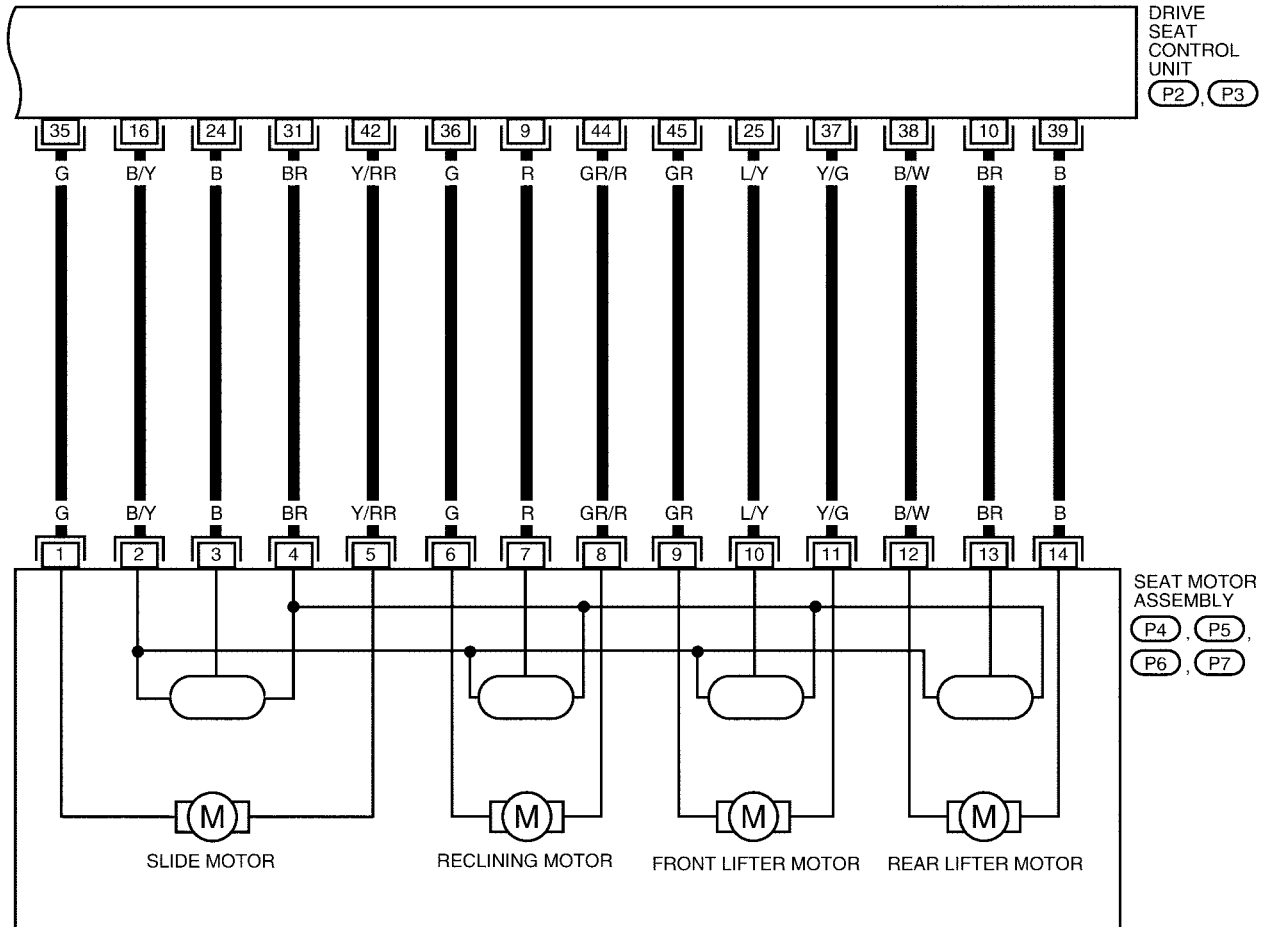

LIWA0082E

AUTOMATIC DRIVE POSITIONER

SE-AUT/DP-09

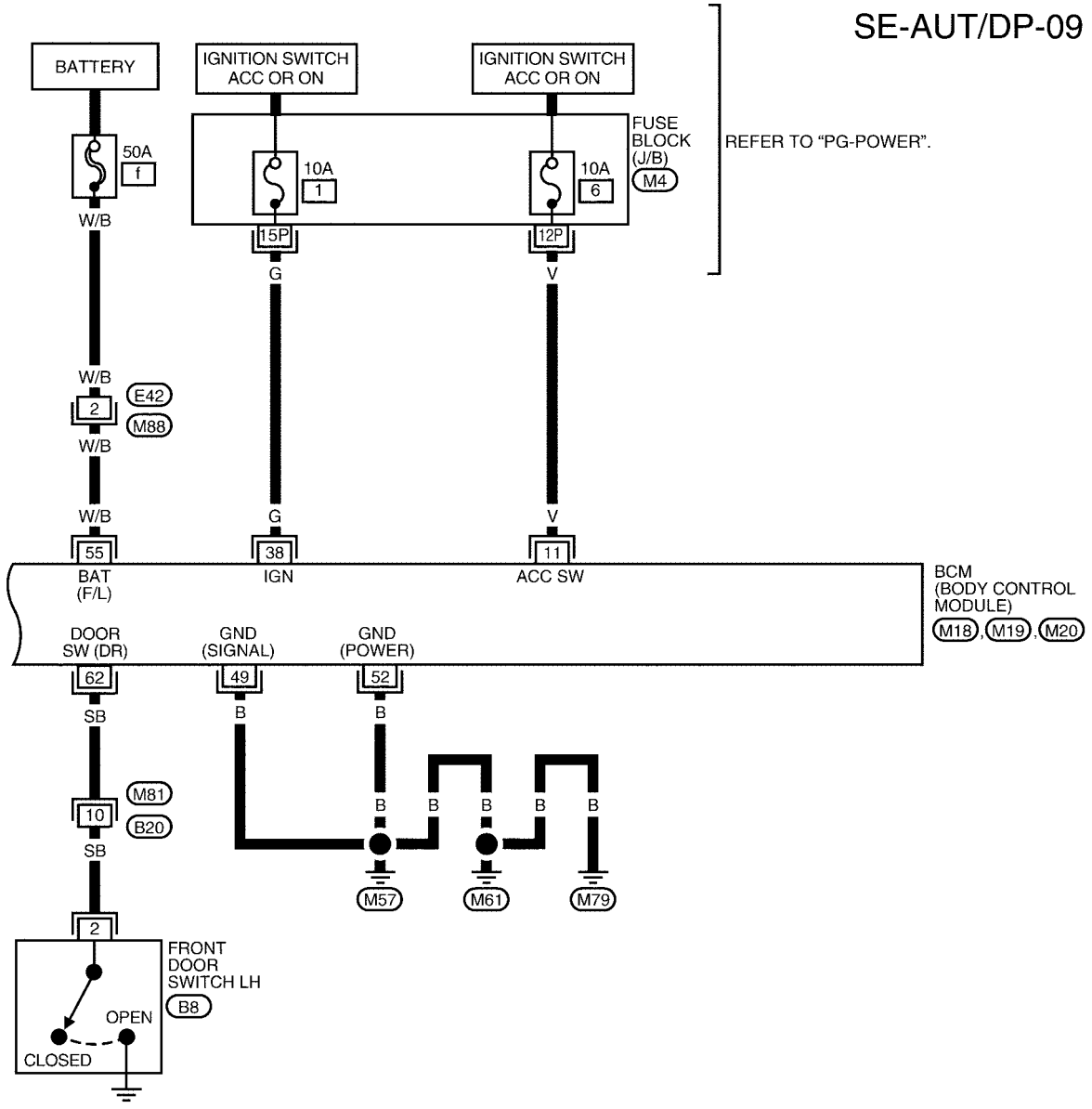

A
B
C
D
E
F
G
H
SE
J
K
L
M

1P	2P	3P	4P	5P	6P	7P	M4		
8P	9P	10P	11P	12P	13P	14P	15P	16P	W

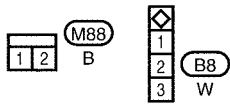
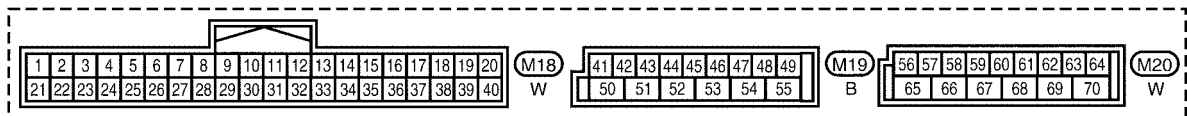

LIWA0083E

AUTOMATIC DRIVE POSITIONER

Terminals and Reference Values for Driver Seat Control Unit

EIS001NV

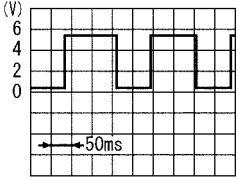
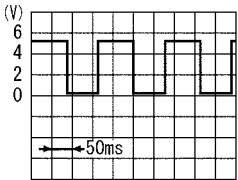
Terminal	Wire Color	Item	Condition	Voltage (V) (Approx)
1	W/B	UART LINE (RX)	—	—
3	BR	CAN-H	—	—
6	B/W	IGN START power supply	Ignition switch START	Battery voltage
8	W	Parking brake switch signal	Parking brake in ON position	0
			Parking brake in other than ON position With ignition key in ignition key cylinder	Battery voltage
9	R	Reclining sensor signal	ON (seat reclining motor operation)	 <p style="text-align: right; font-size: small;">SIIA0692J</p>
			Other than above	0 or 5
10	BR	Rear end lifter sensor signal	ON (rear end lifting motor operation)	 <p style="text-align: right; font-size: small;">SIIA0693J</p>
			Other than above	0 or 5
11	GR/R	Sliding switch RR signal	ON (Sliding switch RR operation)	0
			OFF	Battery voltage
12	P	Reclining switch RR signal	ON (Reclining switch RR operation)	0
			OFF	Battery voltage
13	W	Front lifting switch DOWN signal	ON (front lifting switch DOWN operation)	0
			OFF	Battery voltage
14	GR	Rear lifting switch DOWN signal	ON (rear lifting switch DOWN operation)	0
			OFF	Battery voltage
16	B/Y	Power supply (ENCODER)	—	?
17	GR	UART LINE (TX)	—	—
19	Y/G	CAN-L	—	—
21	SB	Detention switch signal	Selector lever P position	0
			Selector lever other than P position With ignition key in ignition key cylinder	Battery voltage

AUTOMATIC DRIVE POSITIONER

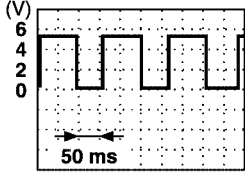
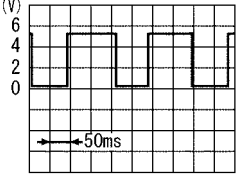
Terminal	Wire Color	Item	Condition	Voltage (V) (Approx)
24	B	Sliding sensor signal	ON (seat sliding motor operation)	 PIIA3277E
			Other than above	
25	L/Y	Front end lifting sensor signal	ON (front end lifting motor operation)	 SIIA0691J
			Other than above.	0 or 5
26	P/B	Sliding switch FR signal	ON (Sliding switch FR operation)	0
			OFF	Battery voltage
27	W/R	Reclining switch FR signal	ON (Reclining switch FR operation)	0
			OFF	Battery voltage
28	BR	Front lifting switch UP signal	ON (front lifting switch UP operation)	0
			OFF	Battery voltage
29	Y/R	Rear lifting switch UP signal	ON (rear lifting switch UP operation)	0
			OFF	Battery voltage
31	BR	Sensor ground	Ignition switch ON	0
32	B/W	Ground	Ignition switch ON	0
33	Y	Battery power supply	Ignition switch OFF (PTC)	Battery voltage
35	G	Sliding motor FR output signal	Sliding switch forward operation (Motor operated)	Battery voltage
			OFF	0
36	G	Reclining motor FR output signal	Reclining switch forward operation (Motor operated)	Battery voltage
			OFF	0
37	Y/G	Front end lifting motor DOWN output signal	Front end lifting switch downward operation (Motor operated)	Battery voltage
			OFF	0
38	B/W	Rear end lifting motor UP output signal	Rear end lifting switch upward operation (Motor operated)	Battery voltage
			OFF	0
39	B	Rear end lifting motor DOWN output signal	Rear end lifting switch downward operation (Motor operated)	Battery voltage
			OFF	0
40	Y/R	Battery power supply	Ignition switch OFF (FUSE)	Battery voltage
42	Y/R	Sliding motor RR output signal	Sliding switch backward operation (Motor operated)	Battery voltage
			OFF	0

A
B
C
D
E
F
G
H
I
J
K
L
M

SE

AUTOMATIC DRIVE POSITIONER

Terminal	Wire Color	Item	Condition	Voltage (V) (Approx)
44	GR/R	Reclining motor RR output signal	Reclining switch backward operation (Motor operated)	Battery voltage
			OFF	0
45	GR	Front end lifting motor UP output signal	Front end lifting switch upward operation (Motor operated)	Battery voltage
			OFF	0
48	BR	Ground	Ignition switch ON	0

Terminals and Reference Values for Automatic Drive Positioner Control Unit

EIS001NY

TERMINAL	WIRE COLOR	ITEM	CONDITION	VOLTAGE (V) (Approx)
1	Y/G	Tilt switch signal UP	UP operation	0
			OFF	5
2	LG/R	Changeover switch signal RH	RH position	0
			Neutral position	5
3	Y/B	Mirror switch signal UP	UP position	0
			Neutral position	5
4	V/W	Mirror switch signal LEFT	LEFT position	0
			Neutral position	5
5	R/B	Mirror sensor signal RH VERTICAL	Door mirror RH UP or DOWN operation	Changes between 3.4 and 0.6
6	L/Y	Mirror sensor signal LH VERTICAL	Door mirror LH UP or DOWN operation	Changes between 3.4 and 0.6
7	O/L	Tilt sensor input	Tilt position TOP	2
			Tilt position BOTTOM	4
9	L/W	Power seat memory switch 1 signal	Memory switch 1 ON	0
			Memory switch 1 OFF	5
10	R	UART LINE (TX)	—	—
11	P/L	Telescopic switch signal FORWARD	Forward operation	0
			OFF	0
12	0	Power seat memory switch inductor 1 signal	Memory switch 1 ON	1
			Memory switch 1 OFF	Battery voltage
13	P	Power seat memory switch inductor 2 signal	Memory switch 2 ON	1
			Memory switch 2 OFF	Battery voltage
14	GR/R	Mirror motor signal RH UP	UP operation	1.5 - Battery voltage
			OFF	0
15	L/Y	Mirror motor signal RH LEFT	LEFT operation	1.5 - Battery voltage
			OFF	0
16	G/B	Mirror motor signal LH DOWN	DOWN operation	1.5 - Battery voltage
			OFF	0
		Mirror motor signal LH RIGHT	RIGHT operation	1.5 - Battery voltage
			OFF	0
17	LG/B	Tilt switch signal DOWN	DOWN operation	0
			OFF	5

AUTOMATIC DRIVE POSITIONER

TERMINAL	WIRE COLOR	ITEM	CONDITION	VOLTAGE (V) (Approx)
18	L/R	Changeover switch signal LH	LH position	0
			Neutral position	5
19	L/B	Mirror switch signal DOWN	DOWN position	0
			Neutral position	5
20	BR/Y	Mirror switch signal RIGHT	RIGHT position	0
			Neutral position	5
21	L/W	Mirror sensor signal RH HORIZONTAL	Door mirror RH LEFT or RIGHT operation	Changes between 3.4 and 0.6
22	G/R	Mirror sensor signal LH HORIZONTAL	Door mirror LH LEFT or RIGHT operation	Changes between 3.4 and 0.6
23	R/Y	Telescopic sensor input	Telescopic position TOP	2
			Telescopic position BOTTOM	4
24	R/B	Power seat set switch signal	Set switch ON	0
			Set switch OFF	5
25	V	Power seat memory switch 2 signal	Memory switch 2 ON	0
			Memory switch 2 OFF	5
26	R/W	UART LINE (RX)	—	—
27	G/W	Telescopic switch signal BACKWARD	BACKWARD operation	0
			OFF	5
30	L/R	Mirror motor signal RH DOWN	DOWN operation	1.5 - Battery voltage
			OFF	0
		Mirror motor signal RH RIGHT	RIGHT operation	1.5 - Battery voltage
			OFF	0
31	V/R	Mirror motor signal LH UP	UP operation	1.5 - Battery voltage
			OFF	0
32	BR	Mirror motor signal LH LEFT	LEFT operation	1.5 - Battery voltage
			OFF	0
33	W/L	Sensor power supply	Ignition switch OFF	5
34	Y/R	Battery power supply (FUSE)	Ignition switch OFF	Battery voltage
35	G/Y	Tilt motor signal UP	UP operation	Battery voltage
			OFF	0
36	R	Telescopic motor signal FORWARD	FORWARD operation	Battery voltage
			OFF	0
39	W/R	Battery power supply (PTC)	Ignition switch OFF	Battery voltage
40	B	Ground	Ignition switch ON	0
41	Y	Sensor ground	Ignition switch ON	0
42	G/W	Tilt motor DOWN signal	DOWN operation	Battery voltage
			OFF	0
44	G	Telescopic motor signal REAR	BACKWARD operation	Battery voltage
			OFF	0
48	B	Ground	Ignition switch ON	0

A
B
C
D
E
F
G
H
SE
J
K
L
M

AUTOMATIC DRIVE POSITIONER

Terminals and Reference Values for BCM

EIS001P9

Terminal	Wire Color	Item	Condition	Voltage (V) (Approx)
11	V	Ignition switch (ACC)	—	Battery voltage
37	B/R	Ignition key switch (insert)	Key inserted → Key removed from key cylinder	Battery voltage → 0V
38	G/R	Ignition switch (ON)	—	Battery voltage
39	L	CAN H	—	—
40	Y	CAN L	—	—
49	B	Ground	—	—
52	B	Ground	—	—
55	W/B	Power source (BAT)	—	Battery voltage
62	SB	Front door switch LH	Door Close (OFF) → Open (ON)	Battery voltage → 0V

Trouble Diagnosis WORK FLOW

EIS001O1

1. Check the symptom and customer's requests.
2. Understand the system description. Refer to [SE-11, "System Description"](#) .
3. Perform the preliminary check, refer to [SE-32, "PRELIMINARY CHECK"](#) .
4. Check the self-diagnosis, results using CONSULT-II refer to [SE-37, "Self-diagnosis Results"](#) .
5. Repair or replace depending on the self-diagnostic results.
6. Based on the trouble diagnosis chart, repair or replace the cause of the malfunction. Refer to [SE-40, "SYMPTOM CHART"](#) .
7. Does the automatic drive positioned system operate normally?
If it is normal, GO TO 8.
If it is not normal, GO TO 3.
8. INSPECTION END

PRELIMINARY CHECK

Setting Change Function

The settings of the automatic driving position system can be changed, using CONSULT-II and the display in the center of the instrument panel.

×: Applicable —: Not applicable

Setting item	Content	CONSULT-II (WORK SUPPORT)	Display unit	Default setting	Factory setting
SEAT SLIDE VOLUME SEAT	The distance at retain operation can be selected from the following 3 modes.	40mm	—	×	×
		80mm		—	—
		150mm		—	—
Sliding Driver Seat and Steering Wheel Raise When Entry/ Exiting Vehicle	The seat sliding and steering wheel raise exiting and entry at entry/exit can be selected: ON (operated)–OFF (not operated)	ON	ON: Indicator lamp ON	—	×
		OFF	OFF: Indicator lamp OFF	×	—
Reset custom settings*	All settings to default.	—	Default: Setting button ON	—	—

It is possible to set sliding driver seat and steering wheel raise for entry/exit of vehicle by pressing set switch.

AUTOMATIC DRIVE POSITIONER

Content	Setting change operation	Indicator LEDs
The seat sliding and steering wheel raise turnout and return at entry/exit can be operated.	Press the set switch for than 10 seconds	Blinking twice
The seat sliding and steering wheel raise turnout and return at entry/exit can be not operated.		Blinking once

*: Setting of sliding driver seat and steering wheel raise for entry/exit of vehicle is ON at factory-shipment. But if custom settings are reset, setting turns OFF.

NOTE:

- After the setting is registered, the new setting is effective, even if the battery is disconnected.
- If setting change function cannot be set with CONSULT-II or display, refer to [SE-35, "CONSULT-II FUNCTION"](#).
- If setting change function cannot be set with set switch, refer to [SE-69, "SEAT MEMORY SWITCH CIRCUIT INSPECTION"](#).

BCM Power Supply and Ground Circuit Inspection

1. FUSE INSPECTION

- Check the following fuses and fusible link in the fuse block (J/B) and fuse and fusible link box.

Unit	Terminal No.	Signal name	No.	Location
BCM	55	Battery power supply	f	Fuse and fusible link box
	11	ACC power supply	6	Fuse block (J/B)
	38	IGN power supply	12	Fuse block (J/B)

OK or NG

- OK >> GO TO 2
 NG >> Replace the fuse or fusible link.

2. POWER SUPPLY CIRCUIT INSPECTION

Disconnect BCM connector, and connect vehicle-side connector terminals shown below to positive probe and body ground to negative probe. Measure voltage.

Unit	Terminal No.	Signal name	Ignition switch	Voltage
BCM	55	Battery power supply	OFF	Battery voltage
	11	ACC power supply	ACC	Battery voltage
	38	IGN power supply	ON	Battery voltage

OK or NG

- OK >> GO TO 3
 NG >> Repair or replace harness.

3. GROUND CIRCUIT INSPECTION

Check continuity between BCM vehicle-side connector and body ground.

Unit	Terminal No.	Signal name	Ignition switch	Continuity
BCM	49, 52	Ground	OFF	Yes

OK or NG

- OK >> Power supply and ground circuits are normal.
 NG >> Repair or replace harness.

AUTOMATIC DRIVE POSITIONER

Power Supply And Ground Circuit Inspection

1. CHECK FUSE

Make sure any of the following fuse in the driver seat control unit and automatic drive positioner control unit are blown.

Unit	Power source	Fuse No.
Driver seat control unit	START power supply	9 (10A)
	Battery power supply	3 (10A)
		f (50A)

NOTE:

Refer to [SE-16, "Component Parts and Harness Connector Location"](#) .

OK or NG

OK >> GO TO 2.

NG >> If fuse is blown, be sure to eliminate cause of malfunction before installing new fuse. Refer to [SE-16, "Component Parts and Harness Connector Location"](#) .

2. CHECK POWER SUPPLY CIRCUIT (DRIVER SEAT CONTROL UNIT)

1. Disconnect driver seat control unit connector.
2. Check voltage between driver seat control unit and ground.

Connector	Terminals (Wire color)		Power source	condition	Voltage (V) (Approx)
	(+)	(-)			
P3	33 (Y), 40 (Y/R)	Ground	Battery power supply	Ignition switch OFF	Battery voltage
P2	6 (B/W)	Ground	START power supply	Ignition switch START	Battery voltage

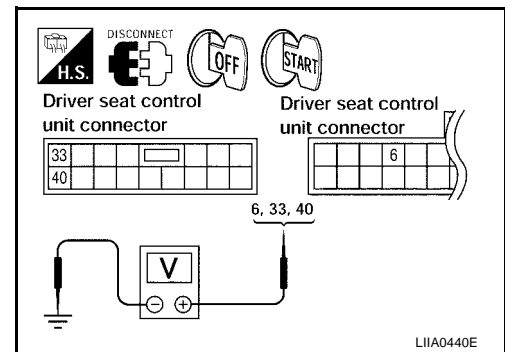

OK or NG

OK >> GO TO 3.

NG >> Check harness for open and short between driver seat control unit and fuse block (J/B).

3. CHECK GROUND CIRCUIT (DRIVER SEAT CONTROL UNIT)

1. Turn ignition switch OFF.
2. Check continuity between the driver seat control unit connector P2 terminal 32 (B/W), P3 terminal 48 (BR) and ground.

32 (B/W) – Ground : Continuity should exist.

48 (BR) – Ground : Continuity should exist.

OK or NG

OK >> Driver seat control unit circuit check is ON, GO TO 4.

NG >> Repair or replace harness between driver seat control unit and ground.

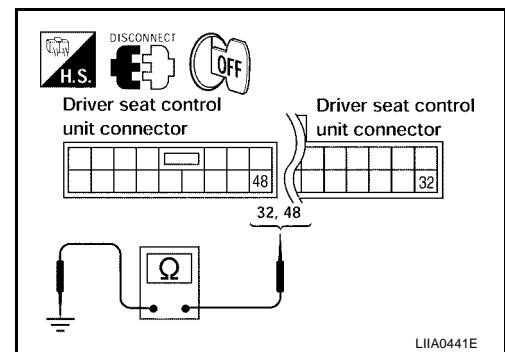

AUTOMATIC DRIVE POSITIONER

4. CHECK POWER SUPPLY CIRCUIT (AUTOMATIC DRIVE POSITIONER CONTROL UNIT)

1. Disconnect automatic drive positioner control unit connector.
2. Check voltage between automatic drive positioner control unit connector M42 terminal 34 (Y/R), 39 (W/R) and ground.

34 (Y/R) – Ground : Battery voltage
39 (W/R) – Ground : Battery voltage

OK or NG

- OK >> GO TO 5.
 NG >> Repair or replace harness between driver seat control unit and fuse block (J/B).

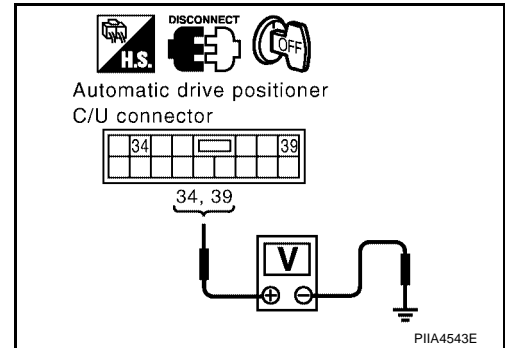

5. CHECK GROUND CIRCUIT (AUTOMATIC DRIVE POSITIONER CONTROL UNIT)

Check continuity between the automatic drive positioner control unit connector M42 terminal 40 (B), 48 (B) and ground.

40 (B) – Ground : Continuity should exist.
48 (B) – Ground : Continuity should exist.

OK or NG

- OK >> Automatic drive positioner control unit circuit is OK.
 NG >> Repair or replace harness between automatic drive positioner control unit and ground.

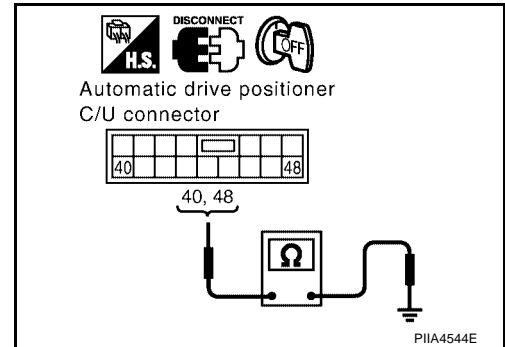

CONSULT-II FUNCTION

The following functions are executed by combining data received and command transmitted via the communication line from the driver seat control unit.

CONSULT-II diagnosis items	Inspection item, self-diagnosis mode		Content
AUTO DRIVE POSITIONER	WORK SUPPORT*1		Changes the setting for each function.
	SELF-DIG RESULTS		Perform the self-diagnosis.
	DATA MONITOR	CAN diagnosis support monitor	Displays CAN communication system diagnosis, disabled transmission status, and communication status of each unit communicated with driver seat control unit.
		Selection from menu	Displays the input data to driver seat control unit driver seat control unit and automatic driving positioned control unit on real-time basis.
	ACTIVE TEST		Gives a drive signal to a load to check the operation.
	DRIVER SEAT CONTROL UNIT PART NUMBER		Displays driver seat control unit part No.
BCM*2	DATA MONITOR	Selection from menu	Displays the input data to BCM on real-time basis

*1: For setting seat functions only.

*2: Refer to [BCS-11, "CONSULT-II"](#).

AUTOMATIC DRIVE POSITIONER

CONSULT-II Inspection Procedure

CAUTION:

If CONSULT-II is used with no connection of CONSULT-II CONVERTER, malfunctions might be detected in self-diagnosis depending on control unit which carry out CAN communication.

1. Turn ignition switch "OFF".
2. Connect "CONSULT-II" and "CONSULT-II CONVERTER" to the data link connector.

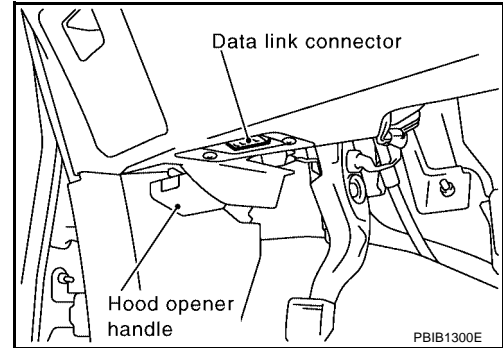

3. Turn ignition switch "ON".
4. Touch "START (NISSAN BASED VHCL)".

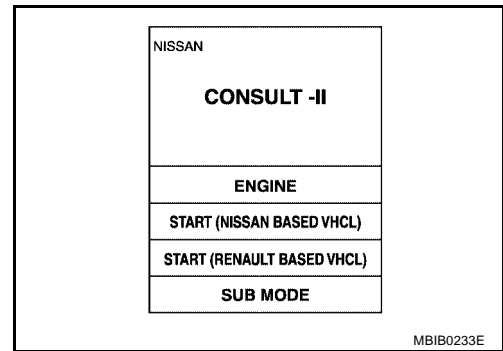

5. Touch "AUTO DRIVE POS" and "BCM".
If "AUTO DRIVE POS." is not indicated, refer to [GI-36, "CONSULT-II Data Link Connector \(DLC\) Circuit"](#).

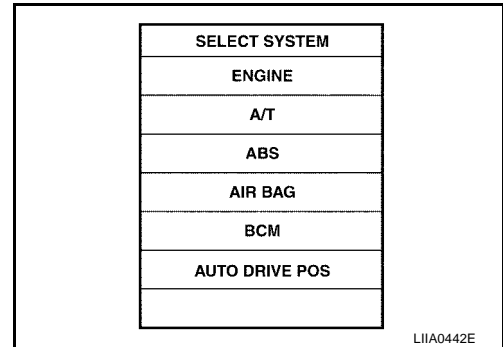

6. Select diagnosis mode.
"DATA MONITOR", "ACTIVE TEST", "SELF-DIAG RESULTS", "ECU PART NUMBER" and "WORK SUPPORT" are available.

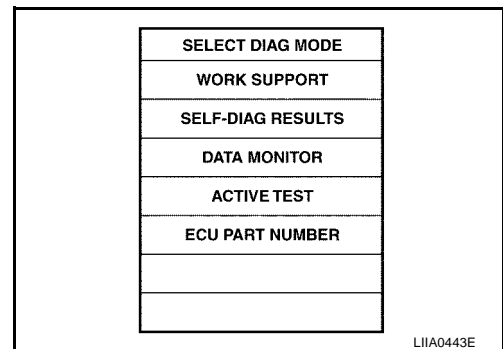

AUTOMATIC DRIVE POSITIONER

Self-diagnosis Results

DISPLAY ITEM LIST

CONSULT-II display	Item	Malfunction is detected when...	Reference page
CAN COMM CIRC [U1000]	CAN communication	Malfunction is detected in CAN communication.	SE-39
SEAT SLIDE [B2112]	Seat slide motor	When any manual and automatic operations are not performed, if any motor operations of seat slide is detected for 0.1 second or more, status is judged "Output error".	SE-43 SE-55
SEAT RECLINING [B2113]	Seat reclining motor	When any manual and automatic operations are not performed, if any motor operations of seat reclining is detected for 0.1 second or more, status is judged "Output error".	SE-44 SE-56
SEAT LIFTER-FR [B2114]	Seat lifting FR motor	When any manual and automatic operations are not performed, if any motor operations of seat lifting FR is detected for 0.1 second or more, status is judged "Output error".	SE-45 SE-57
SEAT LIFTER-RR [B2115]	Seat lifting RR motor	When any manual and automatic operations are not performed, if any motor operations of seat lifting RR is detected for 0.1 second or more, status is judged "Output error".	SE-47 SE-58
STEERING TILT [B2116]	Steering tilt motor	When any manual and automatic operations are not performed, if any motor operations of tilt is detected for 0.1 second or more, status is judged "Output error".	SE-51
TILT SENSOR [B2118]	Steering tilt sensor	When steering tilt sensor detects 0.5V or lower, or 4.5V or higher, for 0.5 seconds or more.	SE-64
STEERING TELESCOPE SENSOR [B2119]	Steering telescopic sensor	When steering telescopic sensor detects 0.5V or lower, or 4.5V or higher, for 0.5 seconds or more.	SE-64
DETENT SW [B2126]	Detente SW	With the A/T selector lever in P position (Detente switch OFF), if the vehicle speed of 7 km/h (4 MPH) or higher was input the detente switch input system is judged malfunctioning.	SE-61
PARKING BRAKE [B2127]	Parking brake	With parking brake use (Parking brake switch ON), if a vehicle speed of 7 km/h (4 MPH) or higher is input, the parking brake switch input system is judged malfunctioning.	SE-63
UART COMM [B2128]	UART communication	Malfunction is detected in UART communication.	SE-87

NOTE:

- Parking brake malfunction will be detected when starting vehicle on grade or driving without releasing parking brake.
- The displays of CAN communication and detection switch display error detecting condition from memory erase to the present on "TIME".
- If error is detected in the past and present error is detected, "CRNT" is displayed.
- If error is detected in the past and present error is not detected, "PAST" is displayed.
- If error has never been detected, nothing is displayed on "TIME".
- Any items other than CAN communication and detection switch count error detection frequency occurred after erase history to "1-127".
- If error was detected in the past, error detection frequency from memory erase to the present is displayed on "TIME".
- If error has never been detected, nothing is displayed on "TIME".
- Can clear the detected memory.
- Normal: Clear memory in normal condition, history is erased and nothing is displayed on "TIME".
- Error: Clear memory in error condition, error is detected again and "1" is displayed on "TIME".

AUTOMATIC DRIVE POSITIONER

Data Monitor

CAN DIAGNOSIS SUPPORT MONITOR

Monitor item [UNIT]		Contents
CAN COMM	[OK/NG]	When CAN communication circuit is malfunctioning, it displays "NG".
CAN CIRC 1	[OK/UNKWN]	Displays [OK/UNKWN] condition of the CAN communication judged by signal input.
CAN CIRC 2	[OK/UNKWN]	Displays [OK/UNKWN] condition of the CAN communication judged by signal input.
CAN CIRC 3	[OK/UNKWN]	Displays [OK/UNKWN] condition of the CAN communication judged by signal input.
CAN CIRC 4	[OK/UNKWN]	Displays [OK/UNKWN] condition of the CAN communication judged by signal input.

SELECTION FROM MEMU

Monitor item [OPERATION or UNIT]		Contents
SLIDE SW-FR	"ON/OFF"	ON/OFF status judged from the sliding switch (FR) signal is displayed.
SLIDE SW-RR	"ON/OFF"	ON/OFF status judged from the sliding switch (RR) signal is displayed.
RECLN SW-FR	"ON/OFF"	ON/OFF status judged from the reclining switch (FR) signal is displayed.
RECLIN SW-RR	"ON/OFF"	ON/OFF status judged from the reclining switch (RR) signal is displayed.
LIFT FR SW-UP	"ON/OFF"	ON/OFF status judged from the FR lifter switch (UP) signal is displayed.
LIFT FR SW-DN	"ON/OFF"	ON/OFF status judged from the FR lifter switch (DOWN) signal is displayed.
LIFT RR SW-UP	"ON/OFF"	ON/OFF status judged from the RR lifter switch (UP) signal is displayed.
LIFT RR SW-DN	"ON/OFF"	ON/OFF status judged from the RR lifter switch (DOWN) signal is displayed.
MIR CON SW-UP	"ON/OFF"	ON/OFF status judged from the door mirror remote control switch (UP) signal is displayed.
MIR CON SW-DN	"ON/OFF"	ON/OFF status judged from the door mirror remote control switch (DOWN) signal is displayed.
MIR CON SW-RH	"ON/OFF"	ON/OFF status judged from the door mirror remote control switch (RIGHT) signal is displayed.
MIR CON SW-LH	"ON/OFF"	ON/OFF status judged from the door mirror remote control switch (LEFT) signal is displayed.
MIR CHNG SW-R	"ON/OFF"	ON/OFF status judged from the door mirror remote control switch (switching to RIGHT) signal is displayed.
MIR CHNG SW-L	"ON/OFF"	ON/OFF status judged from the door mirror remote control switch (switching to LEFT) signal is displayed.
SET SW	"ON/OFF"	ON/OFF status judged from the setting switch signal is displayed.
TILT SW-UP	"ON/OFF"	ON/OFF status judged from the tilt adjusting switch (UP) signal is displayed.
TELESCO SW-FR	"ON/OFF"	ON/OFF status judged from the telescopic adjusting switch (FR) signal is displayed.
MEMORY SW1	"ON/OFF"	ON/OFF status judged from the seat memory switch 1 signal is displayed.
MEMORY SW2	"ON/OFF"	ON/OFF status judged from the seat memory switch 2 signal is displayed.
DETENT SW	"ON/OFF"	The selector lever position "ON (P position) / OFF (other than P position)" judged from the detention switch signal is displayed.
STARTER SW	"ON/OFF"	Ignition key switch ON (START, ON) /OFF (ignition switch IGN, ACC, or OFF) status judged from the ignition switch signal is displayed.
SLIDE PULSE	—	Value (32768) when battery connects is as standard. If it moves forward, the value increases. If it moves backward, the value decreases.
RECLN PULSE	—	Value (32768) when battery connects is as standard. If it moves forward, the value increases. If it moves backward, the value decreases.
LIFT FR PULSE	—	Value (32768) when battery connects is as standard. If it moves forward, the value increases. If it moves backward, the value decreases.

AUTOMATIC DRIVE POSITIONER

Monitor item [OPERATION or UNIT]	Contents
LIFT RR PULSE	— Value (32768) when battery connects is as standard. If it moves forward, the value increases. If it moves backward, the value decreases.
MIR/SEN RH R-L	"ON/OFF" Voltage output from LH door mirror sensor (LH/RH) is displayed.
MIR/SEN RH U-D	"ON/OFF" Voltage output from LH door mirror sensor (UP/DOWN) is displayed.
MIR/SEN LH R-L	"ON/OFF" Voltage output from RH door mirror sensor (LH/RH) is displayed.
MIR/SEN LH U-D	"ON/OFF" Voltage output from RH door mirror sensor (Up/DOWN) is displayed.
PARK BRAKE SW	"ON/OFF" "ON/OFF" status from the parking brake switch signal is displayed.

Active Test

CAUTION:

During vehicle driving, it does not perform active test.

NOTE:

If active test is performed, reset seat memory and key fob interlock drive positioner after performing work.

DISPLAY ITEM LIST

Test item	Description
SEAT SLIDE	The sliding motor is activated by receiving the drive signal.
SEAT RECLINING	The reclining motor is activated by receiving the drive signal.
SEAT LIFTER FR	The front end lifter motor is activated by receiving the drive signal.
SEAT LIFTER RR	The rear end lifter motor is activated by receiving the drive signal.
MEMORY SW INDCTR	The memory switch indicator is lit by receiving the drive signal.
MIRROR MOTOR RH	The RH mirror motor moves the mirror UP/DOWN and LEFT/RIGHT by receiving the drive signal.
MIRROR MOTOR LH	The LH mirror motor moves the mirror UP/DOWN and LEFT/RIGHT by receiving the drive signal.

CAN COMMUNICATION INSPECTION USING CONSULT-II (SELF-DIAGNOSIS)

1. SELF-DIAGNOSTIC RESULT CHECK

CAUTION:

If CONSULT-II is used with no connection of CONSULT-II CONVERTER, malfunctions might be detected in self-diagnosis depending on control unit which carry out CAN communication.

1. Connect to CONSULT-II and select "AUTO DRIVE POS" on the "SELECT DIAG SYSTEM" screen.
2. Select "SELF-DIAG RESULTS" on "SELECT DIAG MODE" screen.
3. Check display content in self-diagnostic results.

CONSULT-II display code	Diagnostic item
U1000	CAN COMM
	CAN CIRC 1
	CAN CIRC 2
	CAN CIRC 3
	CAN CIRC 4

Contents displayed.

No malfunction>>INSPECTION END

Malfunction in CAN communication system>>GO TO 2.

AUTOMATIC DRIVE POSITIONER

2. CHECK SYMPTOM

1. Select "CAN diagnosis support monitor" in data monitor.
2. Select "START" and check display content. Refer to [LAN-8, "CAN COMMUNICATION"](#).

Diagnosis item	Self-diagnostic result content	
	Normal	Not normal (Example)
CAN COMM	OK	NG
CAN CIRC 1	OK	UNKWN
CAN CIRC 2	OK	UNKWN
CAN CIRC 3	OK	UNKWN
CAN CIRC 4	OK	UNKWN

>> After printing the monitor items, go to "CAN System". Refer to [LAN-8, "CAN COMMUNICATION"](#).

SYMPTOM CHART

Symptom	Diagnoses / service procedure	Refer to page
A part of seat system does not operate (both automatically and manually).	1. Sliding motor circuit inspection	SE-43
	2. Reclining motor circuit inspection	SE-44
	3. Front lifter motor circuit inspection	SE-45
	4. Rear lifter motor circuit inspection	SE-47
	5. If the above systems are normal, replace the driver seat control unit	—
A part of door mirror does not operate (both automatically and manually).	1. Mirror motor LH circuit check	SE-48
	2. Mirror motor RH circuit check	SE-50
	3. If the above systems are normal, replace the automatic drive positioner control unit.	—
A part of seat system does not operate (only automatic operation).	1. Sliding sensor circuit inspection	SE-55
	2. Reclining sensor circuit inspection	SE-56
	3. Front lifter sensor circuit inspection	SE-57
	4. Rear lifter sensor circuit inspection	SE-58
	5. If the above systems are normal, replace the driver seat control unit	—
A part of door mirror system does not operate (only automatic operation).	1. Mirror sensor LH circuit check	SE-59
	2. Mirror sensor RH circuit check	SE-60
	3. If the above systems are normal, replace the automatic drive positioner control unit.	—
All the automatic operations do not operate.	1. Detention switch circuit inspection	SE-61
	2. Key switch and key lock solenoid circuit inspection	SE-66
	3. UART communication line circuit inspection	SE-87
	4. Tilt sensor circuit inspection	SE-65
	5. Telescopic sensor circuit inspection	SE-64
	6. If all the above systems are normal, replace the automatic drive positioner control unit.	—

AUTOMATIC DRIVE POSITIONER

Symptom	Diagnoses / service procedure	Refer to page	
A part of seat system does not operate (only manual operation).	1. Sliding switch circuit inspection	SE-71	A
	2. Reclining switch circuit inspection	SE-72	B
	3. Front lifter switch circuit inspection	SE-74	C
	4. Rear lifter switch circuit inspection	SE-75	D
	5. If the above systems are normal, replace the driver seat control unit	-	E
Seat function does not operate (only automatic operation).	1. Seat sensor power supply and ground inspection	SE-42	F
	2. Sliding sensor circuit inspection	SE-55	G
	3. Reclining sensor circuit inspection	SE-56	H
	4. Front lifter sensor circuit inspection	SE-57	I
	5. Rear lifter sensor circuit inspection	SE-58	J
	6. If the above systems are normal, replace the driver seat control unit	-	K
A part of door mirror does not operate (only manual operation).	1. Door mirror remote control switch (change over switch) circuit inspection	SE-77	L
	2. Door mirror remote control switch (mirror switch) switching circuit inspection	SE-79	M
	3. If the above systems are normal, replace the automatic drive positioner control unit	-	N
Only memory switch operation.	1. Seat memory switch circuit inspection	SE-69	O
	2. If the above systems are normal, replace the driver seat control unit	-	P
Seat memory indicator lamps 1 and 2 do not illuminate.	1. Seat memory indicator lamp circuit inspection	SE-85	Q
	2. If all the above systems are normal, replace the driver seat control unit.	-	R
The Entry/Exiting does not operated when door is opened and closed. (The Entry/Exiting operates with key switch)	1. Driver door switch circuit inspection	SE-68	S
	2. If all the above systems are normal, replace the BCM.	-	T
The key fob interlock function does not operated.	1. Key fob interlock function inspection	BL-38	U
	2. Hall the above systems are normal, replace the BCM	-	V
Only seat system does not operate (only manual operation).	1. Power seat switch ground circuit inspection	SE-76	W

SE

AUTOMATIC DRIVE POSITIONER

SEAT SENSOR POWER SUPPLY AND GROUND INSPECTION

1. CHECK SEAT SENSOR HARNESS CONTINUITY

1. Turn ignition switch OFF.
2. Disconnect driver seat control unit connector and seat motor assembly.
3. Check continuity between driver seat control unit connector P2 terminals 16 (B/Y), 31 (BR) and seat motor assembly P4 terminals 2 (B/Y), 4 (BR).

16 (B/Y) – 2 (B/Y) : Continuity should exist.

31 (BR) – 4 (BR) : Continuity should exist.

4. Check continuity between driver seat control unit connector P2 terminals 16 (B/Y), 31 (BR) and ground.

16 (B/Y) – Ground : Continuity should not exist.

31 (BR) – Ground : Continuity should not exist.

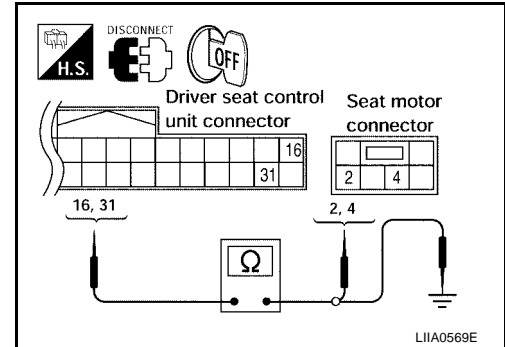

OK or NG

OK >> GO TO 2.

NG >> Repair or replace harness between driver seat control unit and seat motor assembly.

2. CHECK SEAT SENSOR POWER SUPPLY

1. Connect driver seat control unit.
2. Turn ignition switch ON.
3. Check voltage between driver seat control unit connector P2 terminal 16 (B/Y) and ground.

16 (B/Y) – Ground : Battery voltage.

OK or NG

OK >> GO TO 3.

NG >> Replace driver seat control unit.

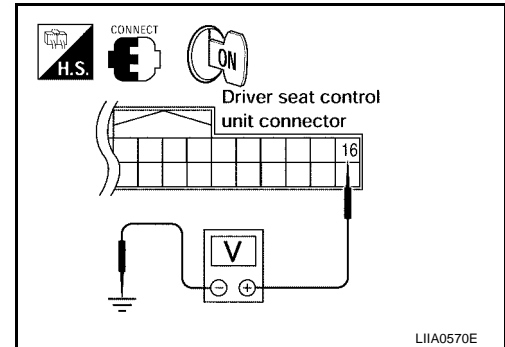

3. CHECK SEAT SENSOR GROUND CIRCUIT

1. Turn ignition switch OFF.
2. Check continuity between driver seat control unit connector P2 terminal 31 (BR) and ground.

31 (BR) – Ground : Continuity should not exist.

OK or NG

OK >> Check the condition of the harness and connector.

NG >> Replace driver seat control unit.

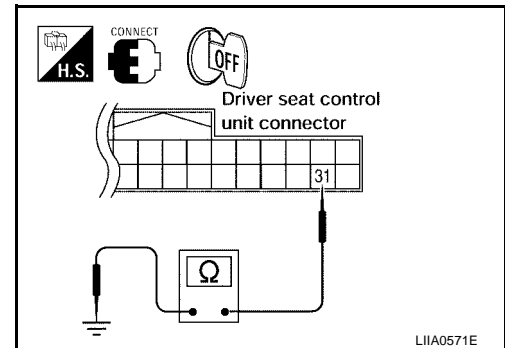

AUTOMATIC DRIVE POSITIONER

SLIDING MOTOR CIRCUIT INSPECTION

1. CHECK SEAT SLIDING MECHANISM

Check the following.

- Operation malfunction caused by sliding rail deformation or pinched harness or other foreign materials
- Operation malfunction caused by foreign materials adhered to the sliding motor or sliding rail connector rod
- Operation malfunction and interference with other parts by poor installation

OK or NG

OK >> GO TO 2.

NG >> Repair the malfunctioning part and check again.

2. CHECK FUNCTION

 **With CONSULT-II**

Check operation with "SEAT SLIDE" in ACTIVE TEST.

Test item	Description
SEAT SLIDE	The sliding motor is activated by receiving the drive signal.

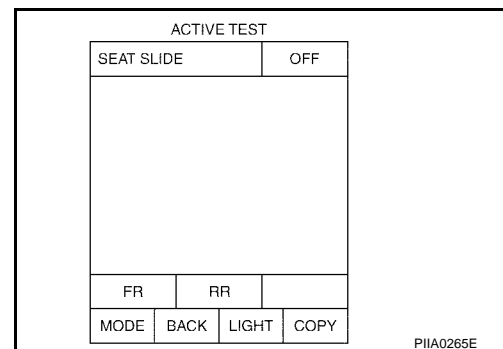

 **Without CONSULT-II**

GO TO 3.

OK or NG

OK >> Sliding motor circuit is OK.

NG >> GO TO 3.

3. CHECK SLIDING MOTOR HARNESS CONTINUITY

1. Turn ignition switch OFF.
2. Disconnect driver seat control unit connector and sliding motor connector.
3. Check continuity between driver seat control unit connector P3 terminals 35 (G), 42 (Y/R) and sliding motor connector P4 terminals 1 (G), 5 (Y/R).

35 (G) – 1 (G) : Continuity should exist.

42 (Y/R) – 5 (Y/R) : Continuity should exist.

4. Check continuity between driver seat control unit connector P3 terminals 35 (G), 42 (Y/R) and ground.

35 (G) – Ground : Continuity should not exist.

42 (Y/R) – Ground : Continuity should not exist.

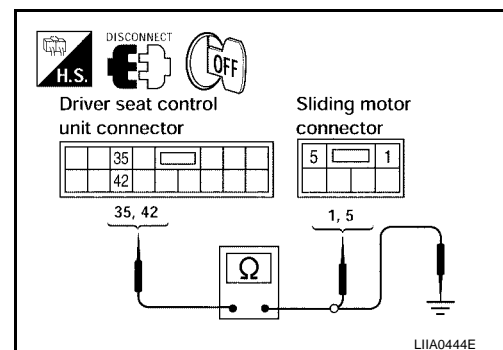

OK or NG

OK >> GO TO 4.

NG >> Repair or replace harness between driver seat control unit and sliding motor.

AUTOMATIC DRIVE POSITIONER

4. CHECK DRIVER SEAT CONTROL UNIT OUTPUT SIGNAL

1. Connect the driver seat control unit connector and sliding motor connector.
2. Check voltage between driver seat control unit connector and ground.

Connector	Terminals (Wire color)		Condition	Voltage (V) (Approx)
	(+)	(-)		
P3	35 (G)	Ground	Sliding switch ON (FR operation)	Battery voltage
			Sliding switch OFF	0
	42 (Y/R)		Sliding switch ON (RR operation)	Battery voltage
			Sliding switch OFF	0

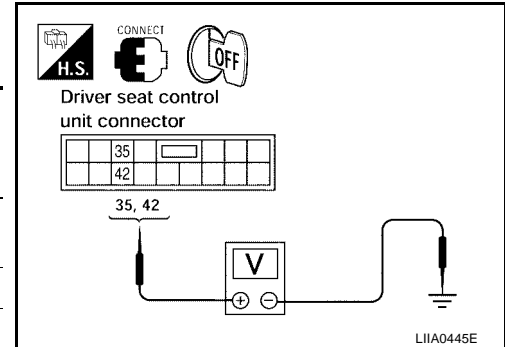

OK or NG

- OK >> Replace sliding motor.
- NG >> Replace driver seat control unit.

RECLINING MOTOR CIRCUIT INSPECTION

1. CHECK SEAT RECLINING MECHANISM

Check the following.

- Operation malfunction caused by an interference with the center pillar or center console
- Operation malfunction and interference with other parts by poor installation

OK or NG

- OK >> GO TO 2.
- NG >> Repair the malfunctioning part and check again.

2. CHECK FUNCTION

With CONSULT-II

Check operation with "SEAT RECLINING" in ACTIVE TEST.

Test item	Description
SEAT RECLINING	The reclining motor is activated by receiving the drive signal.

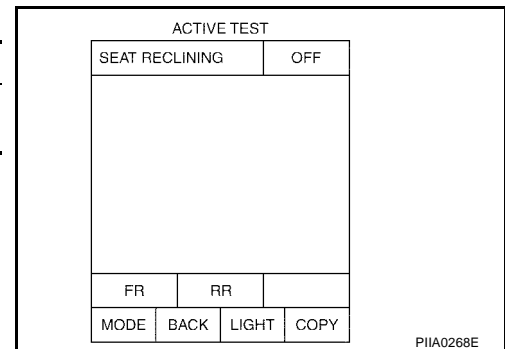

Without CONSULT-II

GO TO 3.

OK or NG

- OK >> Reclining motor circuit is OK.
- NG >> GO TO 3.

AUTOMATIC DRIVE POSITIONER

3. CHECK RECLINING MOTOR HARNESS CONTINUITY

1. Turn ignition switch OFF.
2. Disconnect driver seat control unit connector and reclining motor connector.
3. Check continuity between driver seat control unit connector P3 terminals 36 (G), 44 (GR/R) and reclining motor connector P5 terminals 6 (G), 8 (BR/R).

36 (G) – 6 (G) : Continuity should exist.

44 (GR/R) – 8 (GR/R) : Continuity should exist.

4. Check continuity between driver seat control unit connector P3 terminals 36 (G), 44 (GR/R) and ground.

36 (G) – Ground : Continuity should not exist.

44 (GR/R) – Ground : Continuity should not exist.

OK or NG

OK >> GO TO 4.

NG >> Repair or replace harness between driver seat control unit and reclining motor.

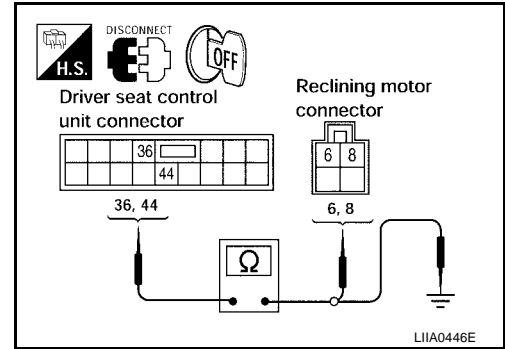

4. CHECK DRIVER SEAT CONTROL UNIT OUTPUT SIGNAL

1. Connect the driver seat control unit and reclining motor connector.
2. Check voltage between driver seat control unit connector and ground.

Connector	Terminals (Wire color)		Condition	Voltage (V) (Approx)
	(+)	(-)		
P3	36 (G)	Ground	Reclining switch ON (FR operation)	Battery voltage
			Reclining switch OFF	0
	44 (GR/R)		Reclining switch ON (RR operation)	Battery voltage
			Reclining switch OFF	0

OK or NG

OK >> Replace reclining motor.

NG >> Replace driver seat control unit.

FRONT LIFTING MOTOR CIRCUIT INSPECTION

1. CHECK FRONT END SEAT LIFTING MECHANISM

Check the following.

- Operation malfunction caused by lifter mechanism deformation or pinched harness or other foreign materials
- Operation malfunction caused by foreign materials adhered to the lifter motor or lead screws
- Operation malfunction and interference with other parts by installation

OK or NG

OK >> GO TO 2.

NG >> Repair the malfunctioning part and check again.

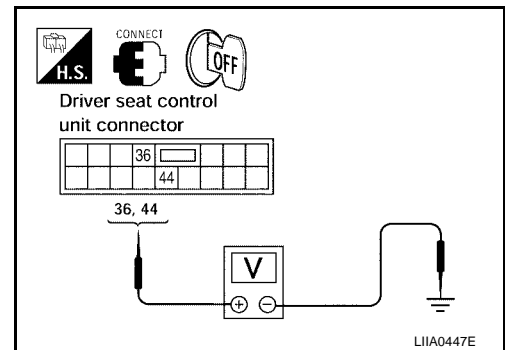

AUTOMATIC DRIVE POSITIONER

2. CHECK FUNCTION

With CONSULT-II

Check operation with "SEAT LIFTER FR" in ACTIVE TEST.

Test item	Description
SEAT LIFTER FR	The front end lifter motor is activated by receiving the drive signal.

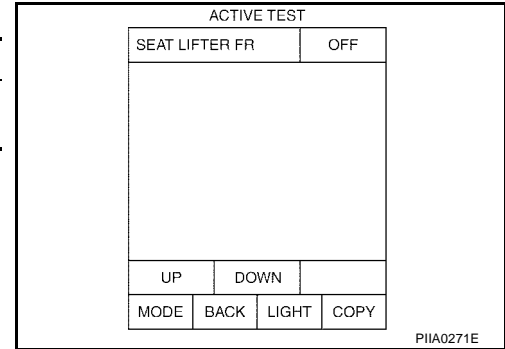

Without CONSULT-II

GO TO 3.

OK or NG

- OK >> Front lifting motor circuit is OK.
- NG >> GO TO 3.

3. CHECK FRONT LIFTING MOTOR HARNESS CONTINUITY

1. Turn ignition switch OFF.
2. Disconnect driver seat control unit connector and front lifting motor connector.
3. Check continuity between driver seat control unit connector P3 terminals 37 (Y/G), 45 (GR) and front lifting motor connector P6 terminals 9 (GR), 11 (Y/G).

37 (Y/G) – 11 (Y/G) : Continuity should exist.

45 (GR) – 9 (GR) : Continuity should exist.

4. Check continuity between driver seat control unit connector P3 terminals 37 (Y/G), 45 (GR) and ground.

37 (Y/G) – Ground : Continuity should not exist.

45 (GR) – Ground : Continuity should not exist.

OK or NG

- OK >> GO TO 4.
- NG >> Repair or replace harness between driver seat control unit and front lifting motor.

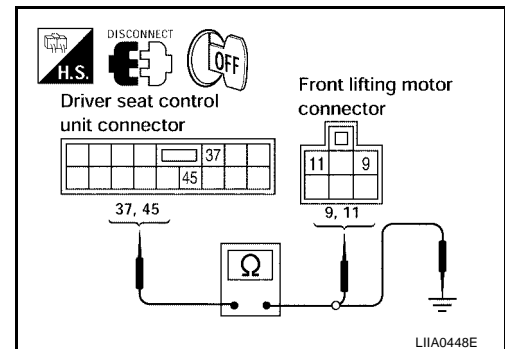

AUTOMATIC DRIVE POSITIONER

4. CHECK DRIVER SEAT CONTROL UNIT OUTPUT SIGNAL

1. Connect the driver seat control unit connector and front lifting motor connector.
2. Check voltage between driver seat control unit connector and ground.

Connector	Terminals (Wire color)		Condition	Voltage (V) (Approx)
	(+)	(-)		
P3	45 (GR)	Ground	Front lifting switch ON (UP operation)	Battery voltage
			Front lifting switch OFF	0
	37 (Y/G)		Front lifting switch ON (DOWN operation)	Battery voltage
			Front lifting switch OFF	0

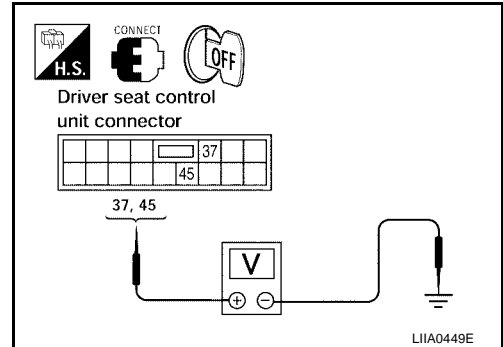

OK or NG

- OK >> Replace front lifting motor.
- NG >> Replace driver seat control unit.

REAR LIFTING MOTOR CIRCUIT INSPECTION

1. CHECK REAR END SEAT LIFTING MECHANISM

Check the following.

- Operation malfunction caused by lifter mechanism deformation or pinched harness or other foreign materials
- Operation malfunction caused by foreign materials adhered to the lifter motor or lead screws
- Operation malfunction and interference with other parts by poor installation

OK or NG

- OK >> GO TO 2.
- NG >> Repair the malfunctioning part and check again.

2. CHECK FUNCTION

With CONSULT-II

Check operation with "SEAT LIFTER RR" in ACTIVE TEST.

Test item	Description
SEAT LIFTER RR	The rear end lifter motor is activated by receiving the drive signal.

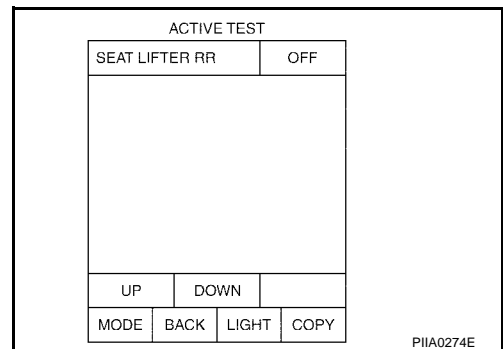

Without CONSULT-II

GO TO 3.

OK or NG

- OK >> Rear lifting motor circuit is OK.
- NG >> GO TO 3.

AUTOMATIC DRIVE POSITIONER

3. CHECK REAR LIFTING MOTOR HARNESS CONTINUITY

1. Turn ignition switch OFF.
2. Disconnect driver seat control unit connector and rear lifting motor connector.
3. Check continuity between driver seat control unit connector P3 terminals 38 (B/W), 39 (B) and lifting motor connector P7 terminals 12 (B/W), 14 (B).

38 (B/W) – 12 (B/W) : Continuity should exist.

39 (B) – 14 (B) : Continuity should exist.

4. Check continuity between driver seat control unit P3 terminals 38 (L), 39 (Y) and ground.

38 (B/W) – Ground : Continuity should not exist.

39 (B) – Ground : Continuity should not exist.

OK or NG

OK >> GO TO 4.

NG >> Repair or replace harness between driver seat control unit and rear lifting motor.

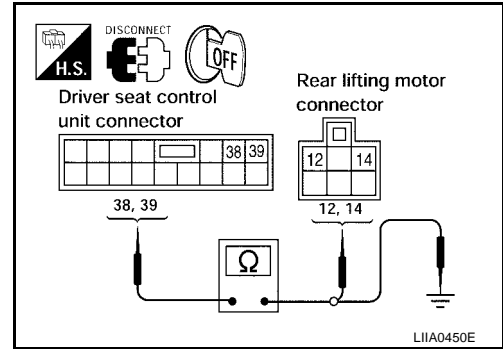

4. CHECK DRIVER SEAT CONTROL UNIT OUTPUT SIGNAL

1. Connect the driver seat control unit and rear lifting motor.
2. Check voltage between driver seat control unit connector and ground.

Connector	Terminals (Wire color)		Condition	Voltage (V) (Approx)
	(+)	(-)		
P3	38 (B/W)	Ground	Rear lifting switch ON (UP operation)	Battery voltage
			Rear lifting switch OFF	0
	39 (B)		Rear lifting switch ON (DOWN operation)	Battery voltage
			Rear lifting switch OFF	0

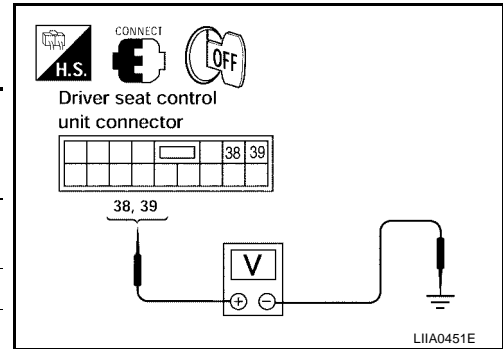

OK or NG

OK >> Replace rear lifting motor.

NG >> Replace driver seat control unit.

MIRROR MOTOR LH CIRCUIT INSPECTION

1. CHECK MIRROR MOTOR LH MECHANISM

Check the following.

- Operation malfunction caused by lifter mechanism deformation or pinched harness or other foreign materials
- Operation malfunction caused by foreign materials adhered to the mirror motor or lead screws
- Operation malfunction and interference with other parts by poor installation

OK or NG

OK >> GO TO 2.

NG >> Repair the malfunctioning part and check again.

AUTOMATIC DRIVE POSITIONER

2. CHECK FUNCTION

With CONSULT-II

Check operation with MIRROR MOTOR LH in ACTIVE TEST.

Test item	Description
MIRROR MOTOR LH	The rear end lifter motor is activated by receiving the drive signal.

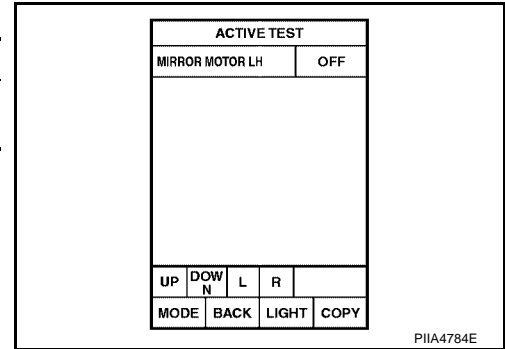

Without CONSULT-II

GO TO 3.

OK or NG

- OK >> Mirror motor LH circuit is OK.
- NG >> GO TO 3.

3. CHECK MIRROR MOTOR LH HARNESS CONTINUITY

- Turn ignition switch OFF.
- Disconnect memory automatic drive positioner control unit connector and door mirror LH connector.
- Check continuity between automatic drive positioner control unit connector M41 terminals 16 (G/B), 31 (V/R), 32 (BR) and door mirror LH connector D4 terminals 8 (G/B), 9 (BR), 10 (V/R).

- 16 (G/B) – 8 (G/B) : Continuity should exist.**
- 31 (V/R) – 10 (V/R) : Continuity should exist.**
- 32 (BR) – 9 (BR) : Continuity should exist.**

- Check continuity between automatic drive positioner control unit connector M41 terminals 16 (G/B), 31 (V/R), 32 (BR) and ground.

- 16 (G/B) – Ground : Continuity should not exist.**
- 31 (V/R) – Ground : Continuity should not exist.**
- 32 (BR) – Ground : Continuity should not exist.**

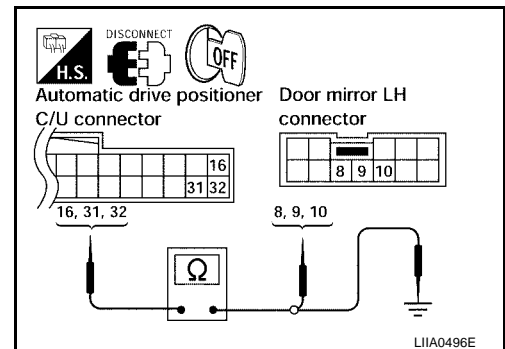

OK or NG

- OK >> GO TO 4.
- NG >> Repair or replace harness between automatic drive positioner control unit and door mirror LH.

AUTOMATIC DRIVE POSITIONER

4. CHECK DRIVER SEAT CONTROL UNIT OUTPUT SIGNAL

1. Connect the automatic drive positioner control unit and door mirror LH.
2. Check voltage between door mirror LH connector and ground.

Connector	Terminals (Wire color)		Condition	Voltage (V) (Approx)
	(+)	(-)		
D4	8 (G/B)	Ground	When motor is DOWN or RIGHT operation	Battery voltage
			Mirror motor LH OFF	0
	9 (BR)		When motor is LEFT operation	Battery voltage
			Mirror motor LH OFF	0
	10 (V/R)		When motor is UP operation	Battery voltage
			Mirror motor LH OFF	0

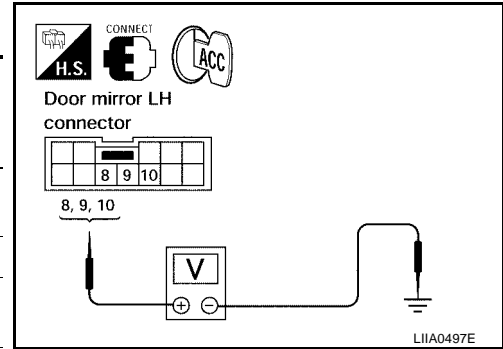

OK or NG

- OK >> Replace door mirror LH.
- NG >> Replace automatic drive positioner control unit.

MIRROR MOTOR RH CIRCUIT INSPECTION

1. CHECK MIRROR MOTOR RH MECHANISM

Check the following.

- Operation malfunction caused by lifter mechanism deformation or pinched harness or other foreign materials
- Operation malfunction caused by foreign materials adhered to the mirror motor or lead screws
- Operation malfunction and interference with other parts by poor installation

OK or NG

- OK >> GO TO 2.
- NG >> Repair the malfunctioning part and check again.

2. CHECK FUNCTION

Ⓟ **With CONSULT-II**

Check operation with MIRROR MOTOR RH" in ACTIVE TEST.

Test item	Description
MIRROR MOTOR RH	The rear end lifter motor is activated by receiving the drive signal.

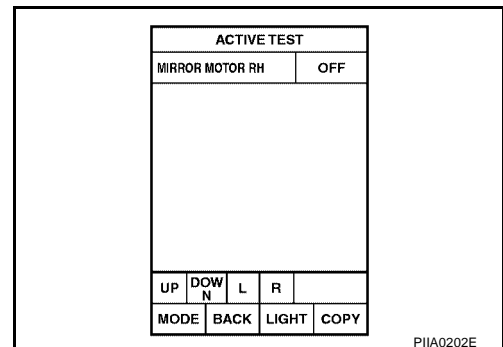

ⓧ **Without CONSULT-II**

GO TO 3.

OK or NG

- OK >> Mirror motor RH circuit is OK.
- NG >> GO TO 3.

AUTOMATIC DRIVE POSITIONER

3. CHECK MIRROR MOTOR RH HARNESS CONTINUITY

1. Turn ignition switch OFF.
2. Disconnect memory automatic drive positioner control unit connector and door mirror RH connector.
3. Check continuity between automatic drive positioner control unit connector M41 terminals 14 (GR/R), 15 (L/Y), 30 (L/R) and door mirror RH connector D107 terminals 8 (L/R), 9 (L/Y), 10 (GR/R).

14 (GR/R) – 10 (GR/R) : Continuity should exist.
15 (L/Y) – 9 (L/Y) : Continuity should exist.
30 (L/R) – 8 (L/R) : Continuity should exist.

4. Check continuity between automatic drive positioner control unit connector M41 terminals 14 (GR/R), 15 (L/Y), 30 (L/R) and ground.

14 (GR/R) – Ground : Continuity should not exist.
15 (L/Y) – Ground : Continuity should not exist.
30 (L/R) – Ground : Continuity should not exist.

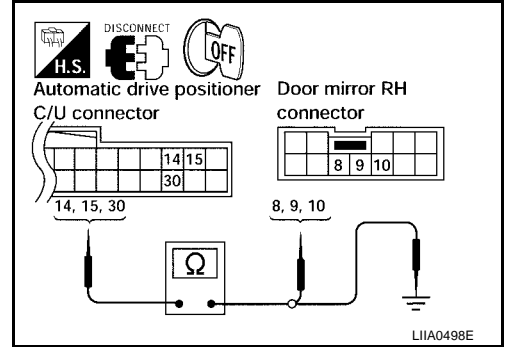

OK or NG

OK >> GO TO 4.

NG >> Repair or replace harness between automatic drive positioner control unit and door mirror RH.

4. CHECK DRIVER SEAT CONTROL UNIT OUTPUT SIGNAL

1. Connect the automatic drive positioner control unit and door mirror RH.
2. Check voltage between door mirror RH connector and ground.

Connector	Terminals (Wire color)		Condition	Voltage (V) (Approx)
	(+)	(-)		
D107	8 (L/R)	Ground	When motor is DOWN or RIGHT operation	Battery voltage
			Mirror motor RH OFF	0
	9 (L/Y)		When motor is LEFT operation	Battery voltage
			Mirror motor RH OFF	0
	10 (GR/R)		When motor is UP operation	Battery voltage
			Mirror motor RH OFF	0

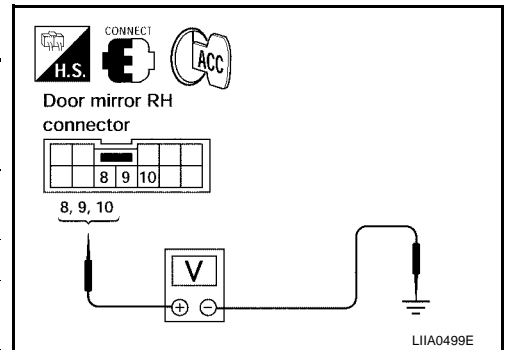

OK or NG

OK >> Replace door mirror RH.

NG >> Replace automatic drive positioner control unit.

STEERING WHEEL TELESCOPIC CIRCUIT INSPECTION

1. CHECK STEERING WHEEL TELESCOPIC ADJUSTING MECHANISM

Check the following.

- Operation malfunction caused by pedal adjusting mechanism deformation or pinched harness or other foreign materials
- Operation malfunction and interference with other parts by poor installation

OK or NG

OK >> GO TO 2.

NG >> Repair the malfunctioning part and check again.

AUTOMATIC DRIVE POSITIONER

2. CHECK FUNCTION

With CONSULT-II

Check operation with "TELESCO MOTOR" in ACTIVE TEST.

Test item	Description
TELESCO MOTOR	The steering wheel telescopic motor is activated by receiving the drive signal.

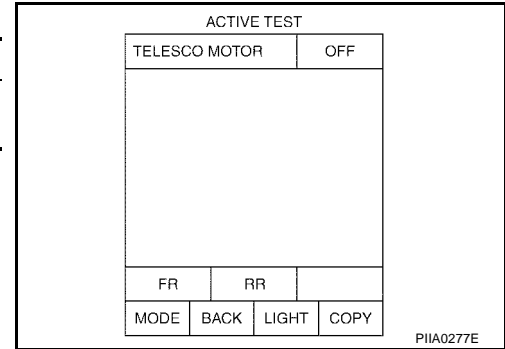

Without CONSULT-II

GO TO 3.

OK or NG

- OK >> Steering wheel telescopic motor circuit is OK.
- NG >> GO TO 3.

3. CHECK STEERING WHEEL TELESCOPIC MOTOR HARNESS CONTINUITY

1. Turn ignition switch OFF.
2. Disconnect automatic drive positioner control unit and steering wheel telescopic motor connector.
3. Check continuity between automatic drive positioner control unit connector M42 terminals 36 (R), 44 (G) and steering wheel telescopic motor connector M66 terminals 4 (R), 5 (G).

36 (R) – 4 (R) : Continuity should exist.

44 (G) – 5 (G) : Continuity should exist.

4. Check continuity between automatic drive positioner control unit connector M42 terminals 36 (R), 44 (R) and ground.

36 (R) – Ground : Continuity should not exist.

44 (G) – Ground : Continuity should not exist.

OK or NG

- OK >> GO TO 4.
- NG >> Repair or replace harness between automatic drive positioner control unit and steering wheel telescopic motor.

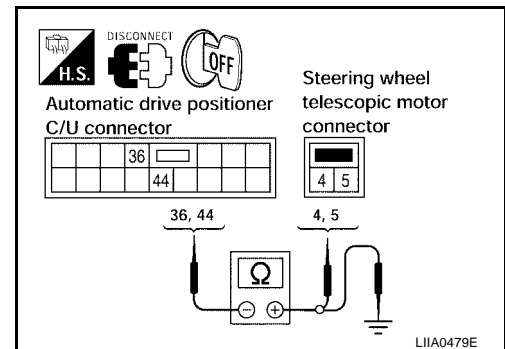

AUTOMATIC DRIVE POSITIONER

4. CHECK AUTOMATIC DRIVE POSITINER CONTROL UNIT OUTPUT SIGNAL

1. Connect the automatic drive positioner control unit connector and pedal adjusting motor connector.
2. Check voltage between automatic drive positioner control unit connector and ground.

Connector	Terminals (Wire color)		Condition	Voltage (V) (Approx)
	(+)	(-)		
M42	36 (R)	Ground	Telescopic switch ON (FR operation)	Battery voltage
			Telescopic switch OFF	0
	44 (G)		Telescopic switch ON (RR operation)	Battery voltage
			Telescopic switch OFF	0

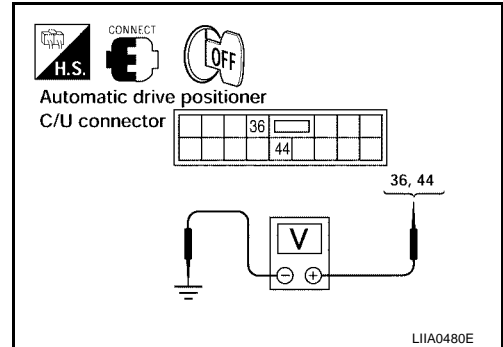

OK or NG

- OK >> Replace steering wheel telescopic motor.
- NG >> Replace automatic drive positioner control unit.

STEERING WHEEL TILT CIRCUIT INSPECTION

1. CHECK STEERING WHEEL TILT MECHANISM

Check the following.

- Operation malfunction caused by pedal adjusting mechanism deformation or pinched harness or other foreign materials
- Operation malfunction and interference with other parts by poor installation

OK or NG

- OK >> GO TO 2.
- NG >> Repair the malfunctioning part and check again.

2. CHECK FUNCTION

With CONSULT-II

Check operation with "TILT MOTOR" in ACTIVE TEST.

Test item	Description
TILT MOTOR	The pedal adjust motor is activated by receiving the drive signal.

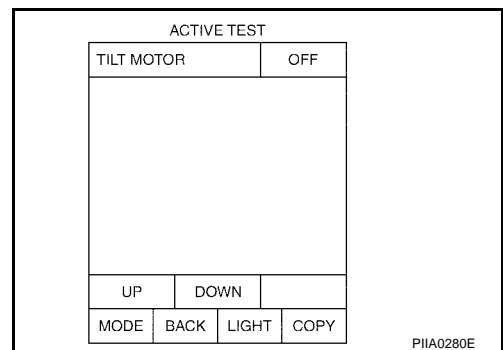

Without CONSULT-II

GO TO 3.

OK or NG

- OK >> Steering wheel tilt motor circuit is OK.
- NG >> GO TO 3.

AUTOMATIC DRIVE POSITIONER

3. CHECK STEERING WHEEL MOTOR HARNESS CONTINUITY

1. Turn ignition switch OFF.
2. Disconnect automatic drive positioner control unit and steering wheel tilt motor connector.
3. Check continuity between automatic drive positioner control unit connector M42 terminals 35 (G/Y), 42 (G/W) and steering wheel tilt motor connector M68 terminals 4 (G/W), 5 (G/Y).

35 (G/Y) – 5 (G/Y) : Continuity should exist.

42 (G/W) – 4 (G/W) : Continuity should exist.

4. Check continuity between automatic drive positioner control unit connector M42 terminals 35 (G/Y), 42 (G/W) and ground.

35 (G/Y) – Ground : Continuity should not exist.

42 (G/W) – Ground : Continuity should not exist.

OK or NG

OK >> GO TO 4.

NG >> Repair or replace harness between automatic drive positioner control unit and steering wheel tilt motor.

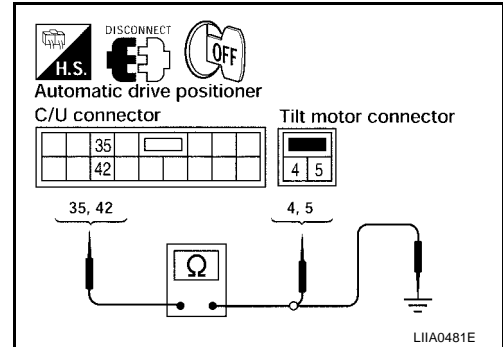

4. CHECK AUTOMATIC DRIVE POSITINER CONTROL UNIT OUTPUT SIGNAL

1. Connect the automatic drive positioner control unit connector and steering wheel tilt motor connector.
2. Check voltage between automatic drive positioner control unit connector and ground.

Connector	Terminals (Wire color)		Condition	Voltage (V) (Approx)
	(+)	(-)		
M42	35 (G/Y)	Ground	Tilt switch ON (UP operation)	Battery voltage
			Tilt switch OFF	0
	42 (G/W)		Tilt switch ON (DOWN operation)	Battery voltage
			Tilt switch OFF	0

OK or NG

OK >> Replace steering wheel tilt motor.

NG >> Replace automatic drive positioner control unit.

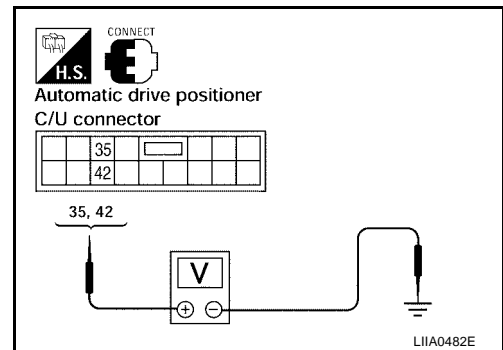

AUTOMATIC DRIVE POSITIONER

SLIDING SENSOR CIRCUIT INSPECTION

1. CHECK FUNCTION

With CONSULT-II

Check operation with "SLIDE PULSE" on the DATA MONITOR to make sure the pulse changes.

Monitor item [OPERATION or UNIT]	Contents
SLIDE PULSE	— The seat sliding position (pulse) judged from the sliding sensor signal is displayed

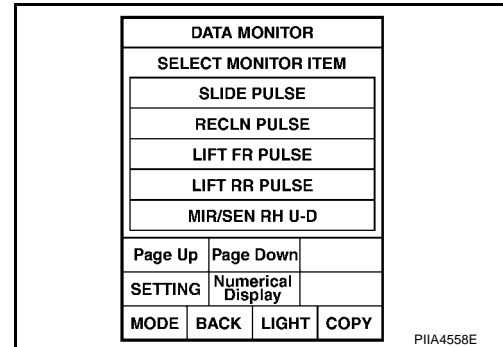

Without CONSULT-II

- Turn ignition switch OFF.
- Check signal between driver seat control unit connector and ground, with oscilloscope.

Connector	Terminals (Wire color)		Condition	Signal
	(+)	(-)		
P2	24 (B)	Ground	Sliding motor operation	

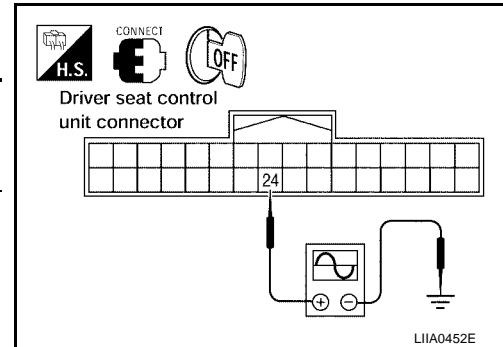

OK or NG

- OK >> Sliding sensor circuit is OK.
 NG >> GO TO 2.

2. CHECK SLIDING SENSOR HARNESS CONTINUITY

- Disconnect driver seat control unit connector and sliding motor connector.
- Check continuity between driver seat control unit connector P2 terminal 24 (B) and sliding motor P4 terminal 3 (B).

24 (B) – 3 (B) : Continuity should exist.

- Check continuity between driver seat control unit P2 terminal 24 (B) and ground.

24 (B) – Ground : Continuity should not exist.

OK or NG

- OK >> Replace sliding motor.
 NG >> Repair or replace harness between driver seat control unit and sliding motor.

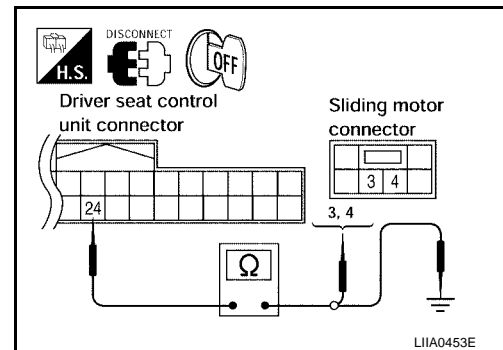

AUTOMATIC DRIVE POSITIONER

RECLINING SENSOR CIRCUIT INSPECTION

1. CHECK FUNCTION

④ With CONSULT-II

Check operation with "RECLINING PULSE" on the DATA MONITOR to make sure the pulse changes.

Monitor item [POERATION or UNIT]	Contents
RECLN PULSE	— The seat reclining position (pulse) judged from the reclining sensor is displayed

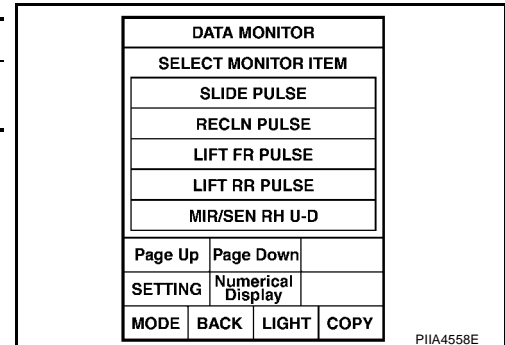

⊗ Without CONSULT-II

1. Turn ignition switch OFF.
2. Check signal between driver seat control unit connector and ground, with oscilloscope.

Connector	Terminals (Wire color)		Condition	Signal
	(+)	(-)		
P2	9 (R)	Ground	Reclining motor operation	

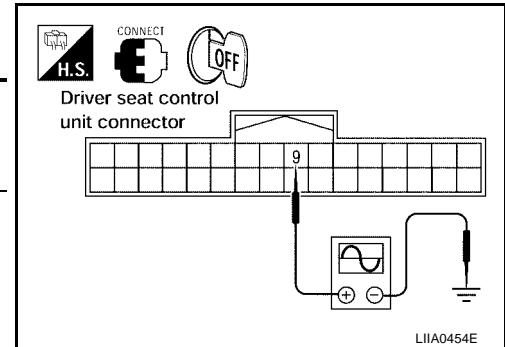

OK or NG

- OK >> Reclining sensor circuit is OK.
 NG >> GO TO 2.

2. CHECK RECLINING SENSOR HARNESS CONTINUITY

1. Disconnect driver seat control unit connector and reclining motor connector.
2. Check continuity between driver seat control unit connector P2 terminal 9 (R) and reclining motor connector P5 terminal 7 (R).

9 (R) – 7 R) : Continuity should exist.

3. Check continuity between driver seat control unit connector P2 terminals 9 (R) and ground.

9 (R) – Ground : Continuity should not exist.

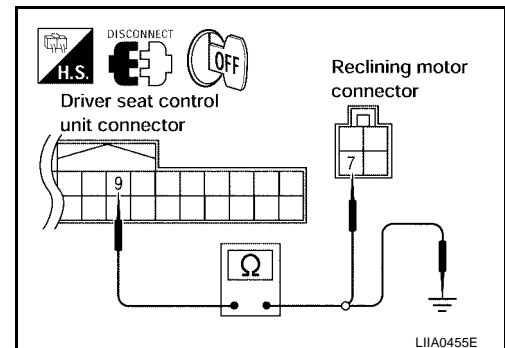

OK or NG

- OK >> Replace reclining motor.
 NG >> Repair or replace harness between connectors driver seat control unit and reclining motor.

AUTOMATIC DRIVE POSITIONER

FRONT LIFTING SENSOR CIRCUIT INSPECTION

1. CHECK FUNCTION

④ With CONSULT-II

Check operation with "LIFT FR PULSE" on the DATA MONITOR to make sure the pulse changes.

Monitor item [OPERATION or UNIT]	Contents
LIFT FR PULSE	— The front lifting position (pulse) judged from the front lifting sensor is displayed

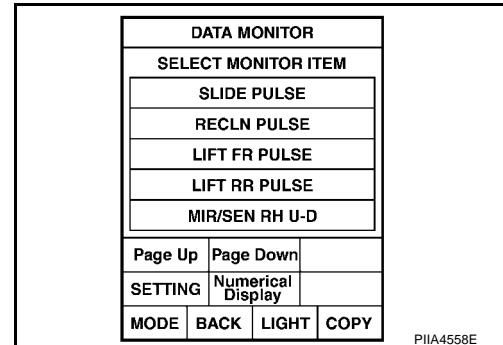

⊗ Without CONSULT-II

- Turn ignition switch OFF.
- Check signal between driver seat control unit connector and ground, with oscilloscope.

Connector	Terminals (Wire color)		Condition	Signal
	(+)	(-)		
P2	25 (L/Y)	Ground	Front lifting motor operation	

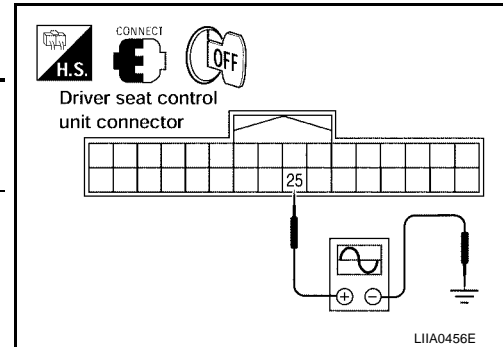

OK or NG

- OK >> Front lifting sensor is OK.
 NG >> GO TO 2.

2. CHECK FRONT LIFTINGS HARNESS CONTINUITY

- Disconnect driver seat control unit connector and front lifting motor connector.
- Check continuity between driver seat control unit connector P2 terminal 25 (L/Y) and front lifting motor connector P6 terminal 10 (L/Y).

25 (L/Y) – 10 (L/Y) : Continuity should exist.

- Check continuity between driver seat control unit connector P2 terminals 25 (L/Y) and ground.

25 (L/Y) – Ground : Continuity should not exist.

OK or NG

- OK >> Replace front lifting motor.
 NG >> Repair or replace harness between driver seat control unit and front lifting motor.

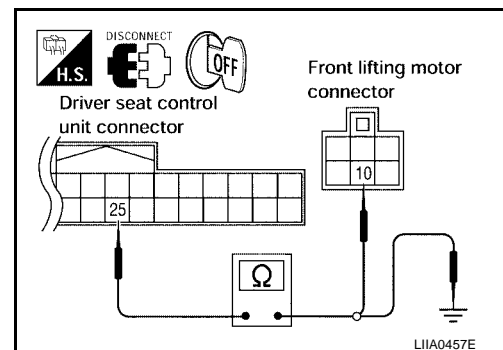

AUTOMATIC DRIVE POSITIONER

REAR LIFTING SENSOR CIRCUIT INSPECTION

1. CHECK REAR END LIFTING SENSOR INPUT/OUTPUT SIGNAL

④ With CONSULT-II

Check operation with "LIFT RP PULSE" on the DATA MONITOR to make sure pulse changes.

Monitor item [OPERATION or UNIT]		
LIFT RR PULSE	—	The rear lifting position (pulse) judged from the rear lifting sensor is displayed.

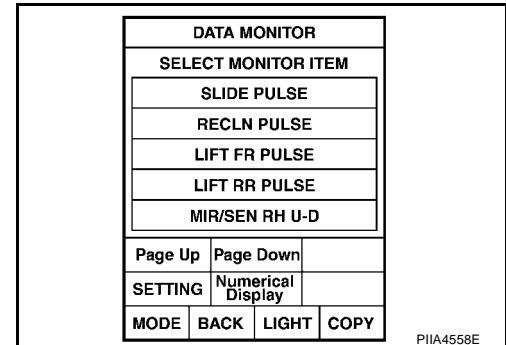

⊗ Without CONSULT-II

1. Turn ignition switch OFF.
2. Check signal between driver seat control unit connector and ground, with oscilloscope.

Connector	Terminals (Wire color)		Condition	Signal
	(+)	(-)		
P2	10 (BR)	Ground	Rear lifting motor operation	

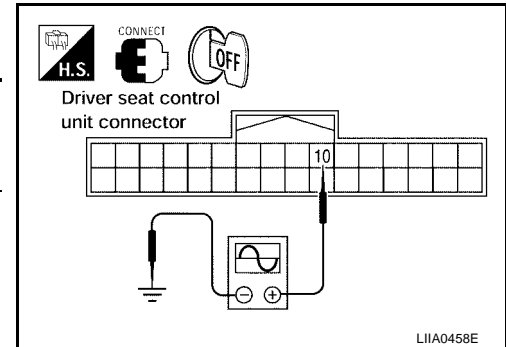

OK or NG

- OK >> Rear lifting sensor circuit is OK.
- NG >> GO TO 2.

2. CHECK REAR LIFTING SENSOR HARNESS CONTINUITY

1. Disconnect driver seat control unit connector and rear lifting motor connector.
2. Check continuity between driver seat control unit connector P2 terminal 10 (BR) and rear lifting motor connector P7 terminal 10 (BR).

10 (BR) – 13 (BR) : Continuity should exist.

3. Check continuity between driver seat control unit connector P2 terminals 10 (BR) and ground.

10 (BR) – Ground : Continuity should not exist.

OK or NG

- OK >> Replace rear lifting motor.
- NG >> Repair or replace harness between driver seat control unit and rear lifting motor.

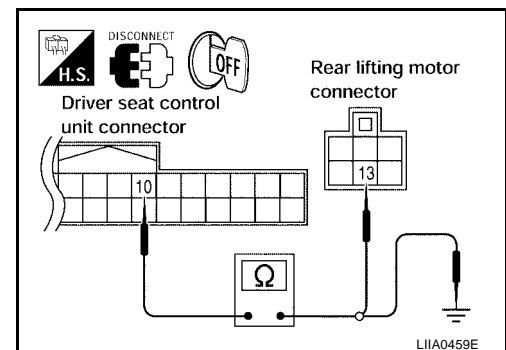

AUTOMATIC DRIVE POSITIONER

MIRROR SENSOR LH CIRCUIT INSPECTION

1. CHECK MIRROR SENSOR LH INPUT/OUTPUT SIGNAL

With CONSULT-II

Check operation with "MIR/SE LH R-L, MIR/SE LH U-D" on the DATA MONITOR to make sure pulse changes.

Monitor item [OPERATION or UNIT]		
MIR/SEN LH R-L	"V"	Voltage output from LH door mirror sensor (LH/RH) is displayed.
MIR/SEN LH U-D	"V"	Voltage output from LH door mirror sensor (UP/DOWN) is displayed.

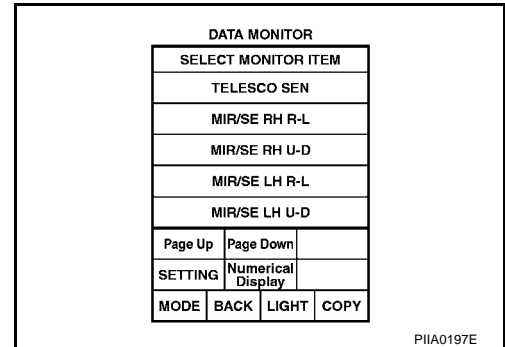

Without CONSULT-II

- Turn ignition switch ACC.
- Check voltage between door mirror LH connector and ground.

Connector	Terminals (Wire color)		Condition	Voltage (V) (Approx.)
	(+)	(-)		
D4	5 (L/Y)	Ground	When motor is UP or DOWN operation	Changes between 3.4 - 0.6
	11 (G/R)		When motor is LEFT or RIGHT operation	Changes between 3.4 - 0.6

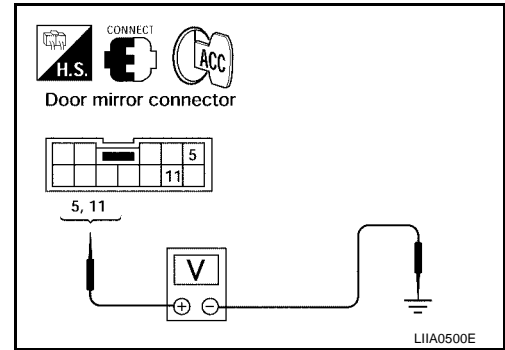

OK or NG

- OK >> Mirror sensor LH circuit is OK.
- NG >> GO TO 2.

2. CHECK HARNESS CONTINUITY 1

- Disconnect automatic drive positioner control unit connector and door mirror LH connector.
- Check continuity between automatic drive positioner control unit connector M42 terminals 33 (W/L), 41 (Y) and door mirror LH connector D4 terminals 4 (W/L), 12 (LG).

33 (W/L) – 4 (W/L) : Continuity should exist.
41 (Y) – 12 (LG) : Continuity should exist.

- Check continuity between driver seat control unit connector M42 terminals 33 (W/L), 41 (Y) and ground.

33 (W/L) – Ground : Continuity should not exist.
41 (Y) – Ground : Continuity should not exist.

OK or NG

- OK >> GO TO 3.
- NG >> Repair or replace harness between automatic drive positioner control unit and door mirror LH.

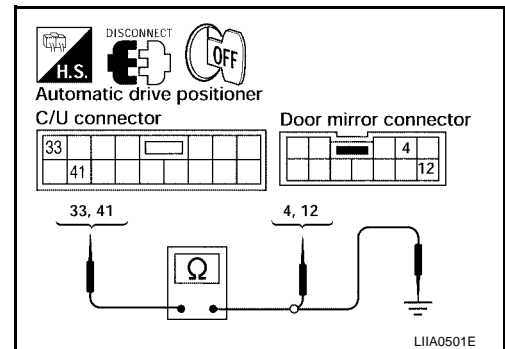

AUTOMATIC DRIVE POSITIONER

3. CHECK HARNESS CONTINUITY 2

1. Disconnect automatic drive positioner control unit connector and door mirror LH connector.
2. Check continuity between automatic drive positioner control unit connector M41 terminals 6 (L/Y), 22 (G/R) and door mirror LH connector D4 terminals 5 (L/Y), 11 (G/R).

6 (L/Y) – 5 (L/Y) : Continuity should exist.
22 (G/R) – 11 (G/R) : Continuity should exist.

3. Check continuity between driver seat control unit connector M41 terminals 6 (L/Y), 22 (G/R) and ground.

6 (L/Y) – Ground : Continuity should not exist.
22 (G/R) – Ground : Continuity should not exist.

OK or NG

- OK >> Replace door mirror LH.
 NG >> Repair or replace harness between automatic drive positioner control unit and door mirror LH.

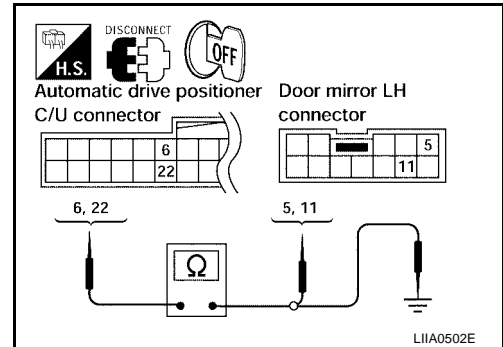

MIRROR SENSOR RH CIRCUIT INSPECTION

1. CHECK MIRROR SENSOR RH INPUT/OUTPUT SIGNAL

With CONSULT-II

Check operation with “MIR/SE RH R-L, MIR/SE RH U-D” on the DATA MONITOR to make sure pulse changes.

Monitor item [OPERATION or UNIT]		
MIR/SEN RH R-L	"V"	Voltage output from RH door mirror sensor (RH/RH) is displayed.
MIR/SEN RH U-D	"V"	Voltage output from RH door mirror sensor (UP/DOWN) is displaced.

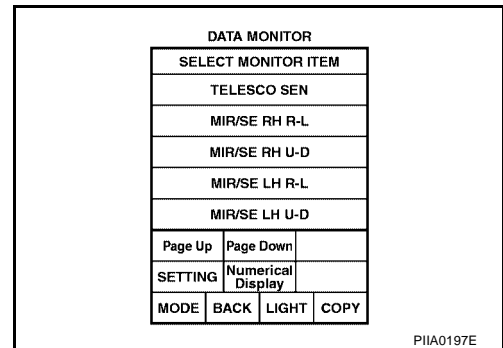

Without CONSULT-II

1. Turn ignition switch ACC.
2. Check voltage between door mirror RH connector and ground.

Connector	Terminals (Wire color)		Condition	Voltage (V) (Approx.)
	(+)	(-)		
D107	5 (R/B)	Ground	When motor is UP or DOWN operation	Changes between 3.4 - 0.6
	11 (L/W)		When motor is LEFT or RIGHT operation	Changes between 3.4 - 0.6

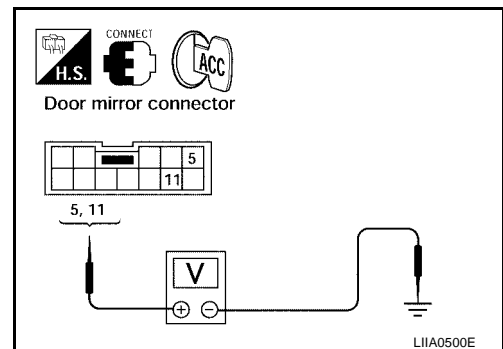

OK or NG

- OK >> Mirror sensor RH circuit is OK.
 NG >> GO TO 2.

AUTOMATIC DRIVE POSITIONER

2. CHECK HARNESS CONTINUITY 1

1. Disconnect automatic drive positioner control unit connector and door mirror RH connector.
2. Check continuity between automatic drive positioner control unit connector M42 terminals 33 (W/L), 41 (Y) and door mirror RH connector D4 terminals 4 (W/L), 12 (LG).

33 (W/L) – 4 (W/L) : Continuity should exist.
41 (Y) – 12 (LG) : Continuity should exist.

3. Check continuity between driver seat control unit connector M42 terminals 33 (W/L), 41 (Y) and ground.

33 (W/L) – Ground : Continuity should not exist.
41 (Y) – Ground : Continuity should not exist.

OK or NG

- OK >> GO TO 3.
 NG >> Repair or replace harness between automatic drive positioner control unit and door mirror RH.

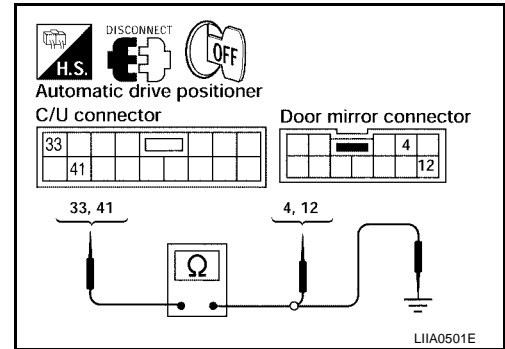

3. CHECK HARNESS CONTINUITY 2

1. Disconnect automatic drive positioner control unit connector and door mirror RH connector.
2. Check continuity between automatic drive positioner control unit connector M41 terminals 5 (R/B), 21 (L/W) and door mirror RH connector D4 terminals 5 (L/Y), 11 (G/R).

5 (R/B) – 5 (L/Y) : Continuity should exist.
21 (L/W) – 11 (G/R) : Continuity should exist.

3. Check continuity between driver seat control unit connector M41 terminals 5 (R/B), 21 (L/W) and ground.

5 (R/B) – Ground : Continuity should not exist.
21 (L/W) – Ground : Continuity should not exist.

OK or NG

- OK >> Replace door mirror RH.
 NG >> Repair or replace harness between automatic drive positioner control unit and door mirror RH.

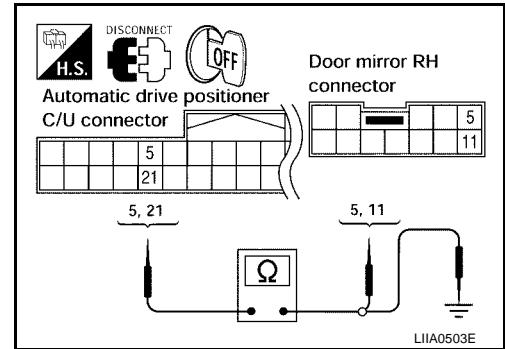

DETENTION SWITCH CIRCUIT INSPECTION (A/T MODEL ONLY)

1. CHECK FUNCTION

With CONSULT-II

Check that when the A/T selector lever is in P position, “DETENT SW” on the DATA MONITOR becomes OFF.

Monitor item [OPERATION or UNIT]	Contents
DETENT SW	“ON/OFF” The selector lever position “P position (OFF)/other than P position (ON)” judged from the detente switch signal is displayed.

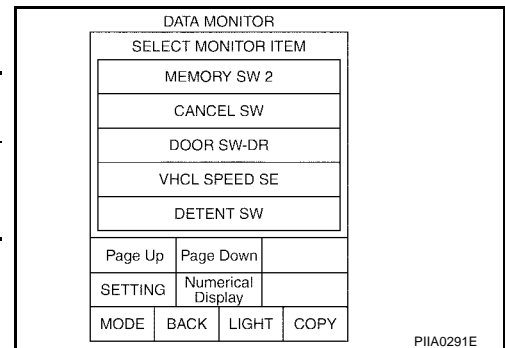

Without CONSULT-II

GO TO 2.

OK or NG

- OK >> Detention switch circuit is OK.
 NG >> GO TO 2.

AUTOMATIC DRIVE POSITIONER

2. CHECK DETENTION SWITCH HARNESS

1. Turn ignition switch OFF.
2. Disconnect A/T device (detention switch) connector and key switch and key lock solenoid connector.
3. Check continuity between A/T device (detention switch) connector M34 terminal 5 (B/R) and key switch and key lock solenoid connector M27 terminal 4 (B/R).

5 (B/R) – 4 (B/R) : Continuity should exist.

4. Check continuity between A/T device (detention switch) connector M34 terminal 5 (B/R) and ground.

5 (B/R) – Ground : Continuity should not exist.

OK or NG

OK >> GO TO 3.

NG >> Repair or replace harness between A/T device (detention switch) and key switch and key lock solenoid.

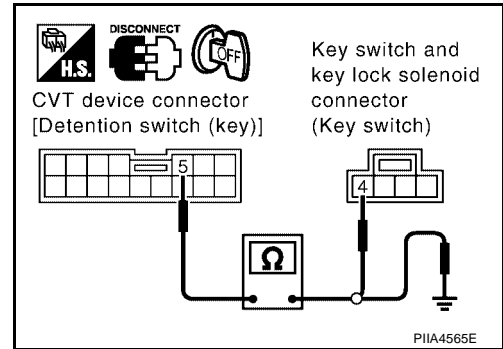

PIIA4565E

3. CHECK DETENTION SWITCH

Check continuity between detection switch as follows.

Connector	Terminals		Condition	Continuity
	(+)	(-)		
M34	5	6	P-position	Continuity should not exist.
			Other than P-position	Continuity should exist.

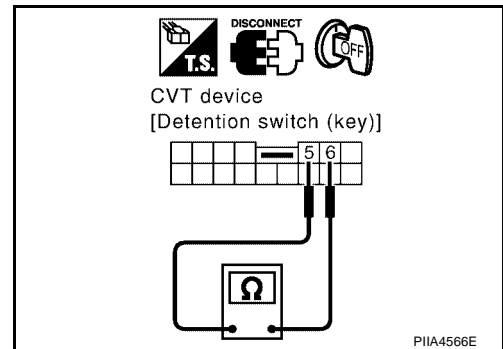

PIIA4566E

OK or NG

OK >> GO TO 4.

NG >> Replace detention switch.

4. CHECK DETENTION SWITCH SIGNAL HARNESS

1. Disconnect driver seat control unit connector.
2. Check continuity between driver seat control unit connector P2 terminal 21 (SB) and A/T device (detention switch) connector M34 terminal 6 (BR/Y).

21 (SB) – 6 (BR/Y) : Continuity should exist.

3. Check continuity between driver seat control unit connector B303 terminal 21 (R/L) and ground.

21 (SB) – Ground : Continuity should not exist.

OK or NG

OK >> Replace driver seat control unit.

NG >> Repair or replace harness between driver seat control unit and A/T device (detention switch).

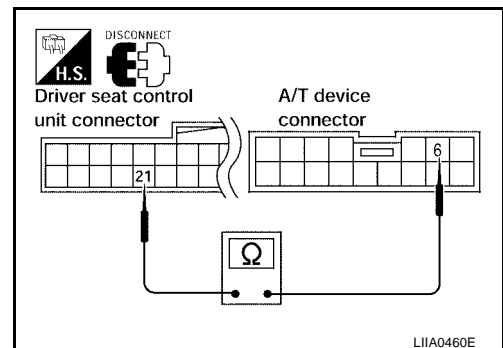

LIIA0460E

AUTOMATIC DRIVE POSITIONER

PARKING BRAKE SWITCH CIRCUIT (M/T MODEL ONLY)

1. CHECK FUNCTION

With CONSULT-II

Check that when the parking brake is released, "PARKING BRAKE" on the DATA MONITOR becomes OFF.

Monitor item [OPERATION or UNIT]		Contents
PARKING BRAKE	"ON/OFF"	The parking brake is released (OFF)/parking brake is engaged (ON) judged from the parking brake switch signal is displayed.

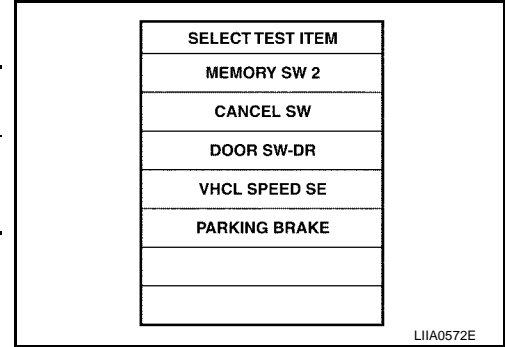

Without CONSULT-II

GO TO 2.

OK or NG

- OK >> Parking brake switch circuit is OK.
- NG >> GO TO 2.

2. CHECK PARKING BRAKE SWITCH SWITCH HARNESS

- Turn ignition switch OFF.
- Disconnect parking brake switch connector and driver seat control unit connector.
- Check continuity between parking brake switch connector M36 terminal + (P/B) and driver seat control unit connector P2 terminal 8 (W).

+ (P/B) – 8 (W) : Continuity should exist.

OK or NG

- OK >> GO TO 3.
- NG >> Repair or replace harness between parking brake switch and driver seat control unit.

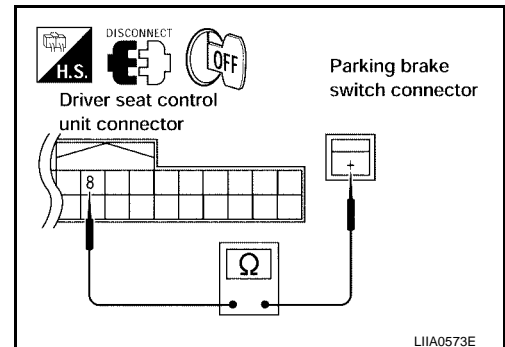

3. CHECK DETENTION SWITCH

Check continuity between parking brake switch as follows.

Connector	Terminals		Condition	Continuity
	(+)	(-)		
M34	+	Ground	Parking brake released	Continuity should not exist.
			Parking brake engaged	Continuity should exist.

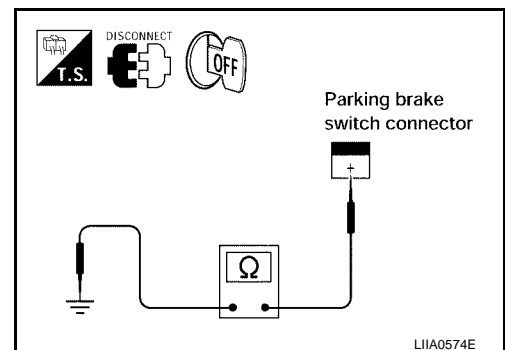

OK or NG

- OK >> INSPECTION END
- NG >> Replace parking brake switch.

AUTOMATIC DRIVE POSITIONER

STEERING WHEEL TELESCOPIC SENSOR CIRCUIT INSPECTION

1. CHECK FUNCTION

④ With CONSULT-II

Operate the pedal adjusting switch with "TELESCO SEN" on the DATA MONITOR to make sure the voltage changes.

Monitor item [OPERATION or UNIT]	Contents
TELESCO SEN	"V" The telescopic position (voltage) judged from the telescopic sensor signal is displayed.

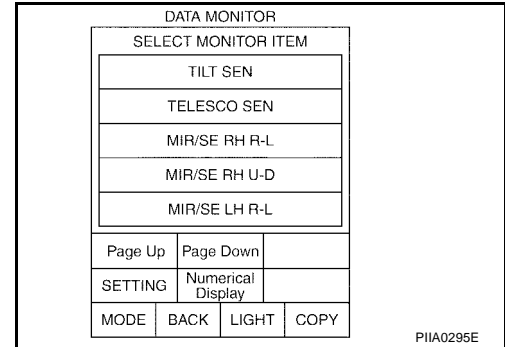

⊗ Without CONSULT-II

1. Turn ignition switch OFF.
2. Check voltage between automatic drive positioner connector and ground.

Connector	Terminals (Wire color)		Condition	Voltage (V) (Approx)
	(+)	(-)		
M41	23 (R/Y)	Ground	Pedal front end position	0.6
			Pedal back end position	4.5

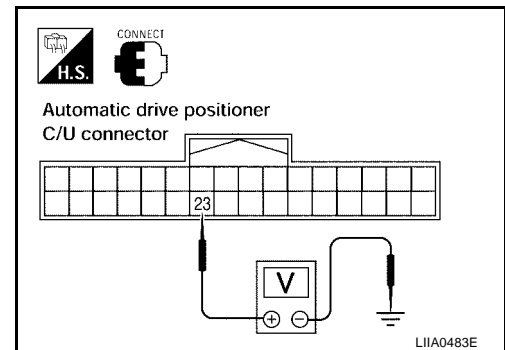

OK or NG

- OK >> Steering wheel telescopic sensor circuit is OK.
 NG >> GO TO 2.

AUTOMATIC DRIVE POSITIONER

2. CHECK HARNESS CONTINUITY

1. Disconnect automatic drive positioner control unit and steering wheel telescopic sensor connector.
2. Check continuity between automatic drive positioner connector M41, M42 terminals 23 (R/Y), 33 (W/L), 41 (Y) and steering wheel telescopic sensor connector M67 terminals 1 (W/L), 2 (R/Y), 3 (Y).

23 (R/Y) – 2 (R/Y) : Continuity should exist.
 33 (W/L) – 1 (W/L) : Continuity should exist.
 41 (Y) – 3 (Y) : Continuity should exist.

3. Check continuity between automatic drive positioner control unit connectors M41, M42 terminals 23 (R/Y), 33 (W/L), 41 (Y) and ground.

23 (R/Y) – Ground : Continuity should not exist.
 33 (W/L) – Ground : Continuity should not exist.
 41 (Y) – Ground : Continuity should not exist.

OK or NG

- OK >> Replace steering wheel telescopic motor.
 NG >> Repair or replace harness between automatic drive positioner and steering wheel telescopic sensor.

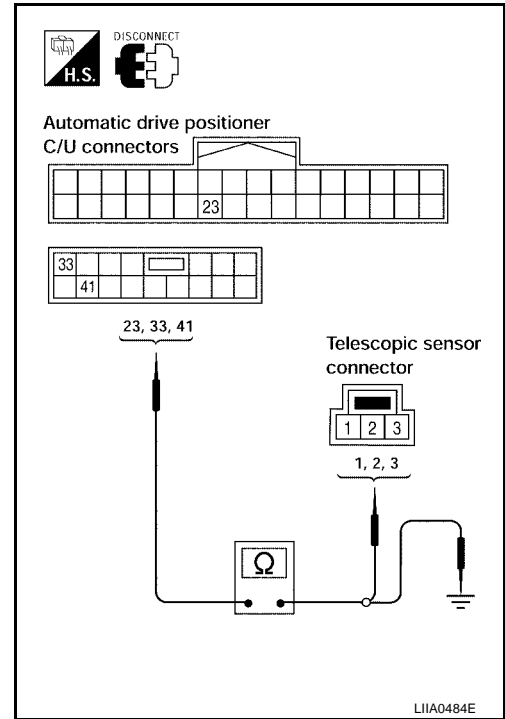

STEERING WHEEL TILT SENSOR CIRCUIT INSPECTION

1. CHECK FUNCTION

With CONSULT-II

Operate the pedal adjusting switch with "TILT SEN" on the DATA MONITOR to make sure the voltage changes.

Monitor item [OPERATION or UNIT]	Contents
TILT SEN	"V" The tilt position (voltage) judged from the tilt sensor signal is displayed.

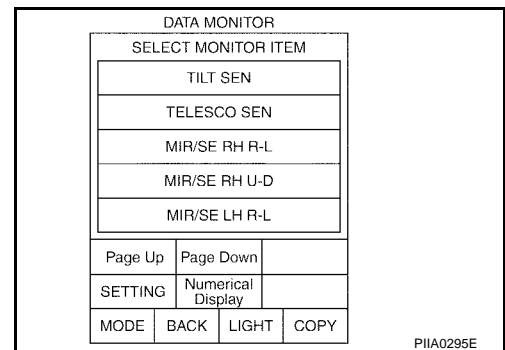

Without CONSULT-II

1. Turn ignition switch OFF.
2. Check voltage between automatic drive positioner connector and ground.

Connector	Terminals (Wire color)		Condition	Voltage (V) (Approx)
	(+)	(-)		
M41	7 (OR/L)	Ground	Pedal front end position	0.6
			Pedal back end position	4.5

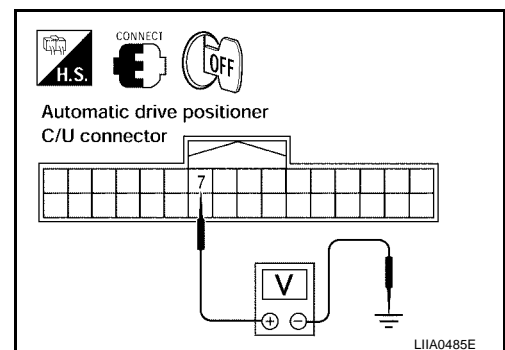

AUTOMATIC DRIVE POSITIONER

OK or NG

- OK >> Steering wheel tilt sensor circuit is OK.
- NG >> GO TO 2.

2. CHECK HARNESS CONTINUITY

1. Disconnect automatic drive positioner control unit and steering wheel tilt sensor connector.
2. Check continuity between automatic drive positioner connector M41, M42 terminals 7 (OR/L), 33 (W/L), 41 (Y) and steering wheel tilt sensor connector M69 terminals 1 (Y), 2 (OR/L), 3 (W/L).

- 7 (OR/L) – 2 (OR/L) : Continuity should exist.**
- 33 (W/L) – 3 (W/L) : Continuity should exist.**
- 41 (Y) – 1 (Y) : Continuity should exist.**

3. Check continuity between automatic drive positioner control unit connectors M41, M42 terminals 7 (OR/L), 33 (W/L), 41 (Y) and ground.

- 7 (OR/L) – Ground : Continuity should not exist.**
- 33 (W/L) – Ground : Continuity should not exist.**
- 41 (Y) – Ground : Continuity should not exist.**

OK or NG

- OK >> Replace steering wheel tilt motor.
- NG >> Repair or replace harness between automatic drive positioner and steering wheel tilt sensor.

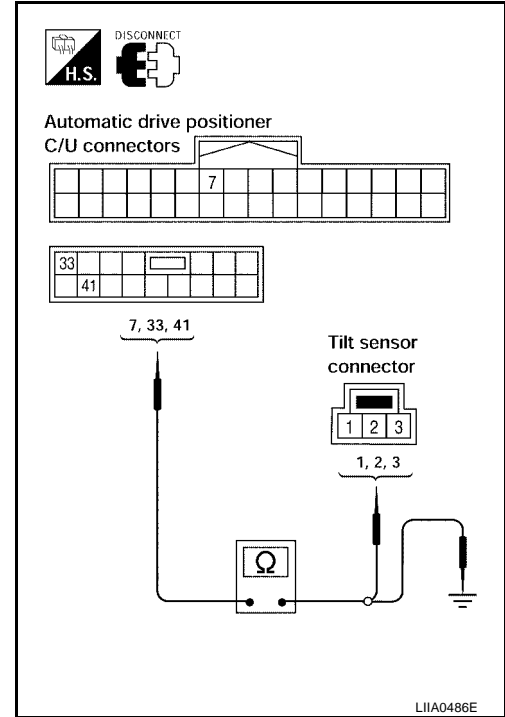

KEY SWITCH AND KEY LOCK SOLENOID CIRCUIT INSPECTION

1. CHECK KEY SWITCH AND KEY LOCK SOLENOID

With CONSULT-II

With "IGN KEY SW" on the DATA MONITOR, Check ON/OFF operation.

Monitor item [OPERATION or UNIT]	Contents
IGN KEY SW	"ON/OFF" Key inserted (ON)/key removed (OFF) status judged from the key-in detection switch is displayed.

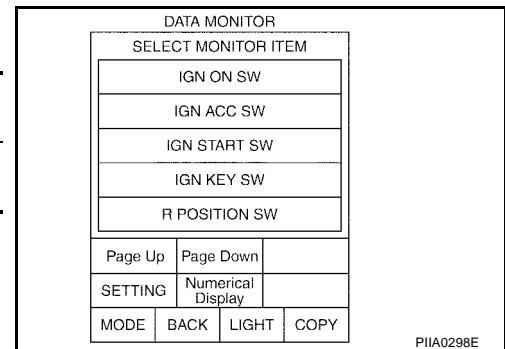

Without CONSULT-II

GO TO 2.

OK or NG

- OK >> Key switch and key lock solenoid circuit is OK.
- NG >> GO TO 2.

AUTOMATIC DRIVE POSITIONER

2. KEY SWITCH AND KEY LOCK SOLENOID (KEY SWITCH) POWER SUPPLY CIRCUIT INSPECTION

1. Turn ignition switch OFF.
2. Disconnect key switch connector and key lock solenoid connector.
3. Check voltage between key switch and key lock solenoid connector M27 terminal 3 (Y/R) and ground.

3 (Y/R) – Ground : Battery voltage.

OK or NG

- OK >> GO TO 3.
 NG >> Check harness between key switch and key lock solenoid and fuse.

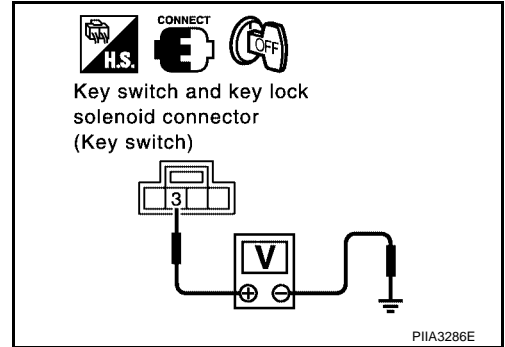

3. CHECK KEY SWITCH AND KEY LOCK SOLENOID (KEY SWITCH)

Check continuity between key switch and key lock solenoid (key switch) as follows.

Connector	Terminals		Condition	Continuity
	(+)	(-)		
M27	3	4	Key is inserted in ignition key cylinder.	Yes
				Key is removed from ignition key cylinder.

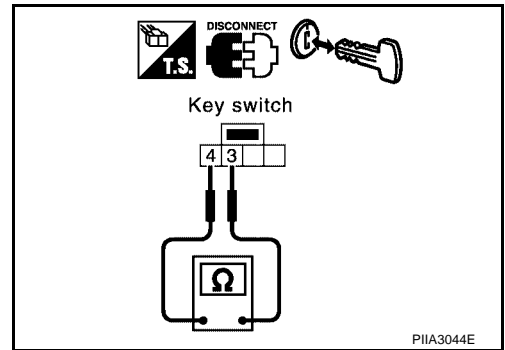

OK or NG

- OK >> GO TO 4.
 NG >> Replace key switch and key lock solenoid (key switch).

4. CHECK HARNESS CONTINUITY

1. Disconnect key switch and key lock solenoid (key switch) connector and BCM connector.
2. Check continuity between key switch and key lock solenoid (key switch) connector M27 terminal 4 (B/R) and BCM connector M18 terminal 37 (B/R).

4 (B/R) – 37 (B/R) : Continuity should exist.

3. Check continuity between key switch and key lock solenoid (key switch) connector M27 terminal 4 (B/R) and ground.

4 (B/R) – Ground : Continuity should not exist.

OK or NG

- OK >> Key switch and key lock solenoid circuit is OK.
 NG >> Repair or replace harness between key switch and key lock solenoid (key switch) and BCM.

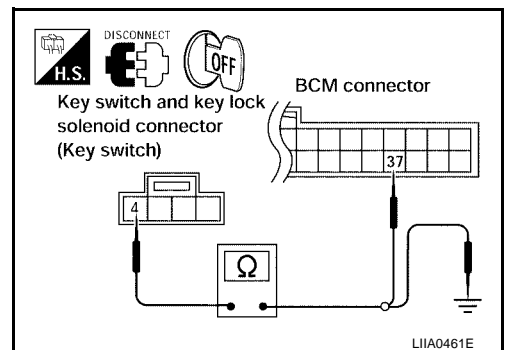

AUTOMATIC DRIVE POSITIONER

FRONT DOOR SWITCH (DRIVER SIDE) CIRCUIT INSPECTION

1. CHECK DOOR SWITCH INPUT SIGNAL

④ With CONSULT-II

Check door switches ("DOOR SW-DR" and "DOOR SW-AS") in "DATA MONITOR" mode with CONSULT-II.

Monitor item	Condition
DOOR SW-DR	OPEN : ON
	CLOSE : OFF

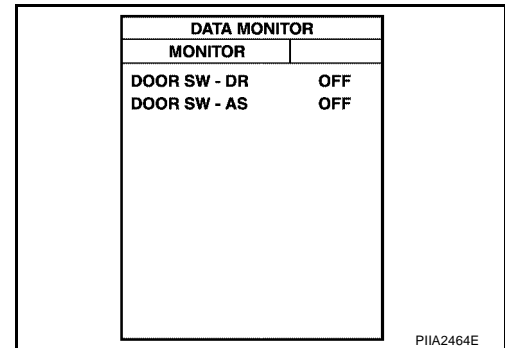

⊗ Without CONSULT-II

Check voltage between BCM connector and ground.

Item	Connector	Terminals (Wire color)		Condition	Voltage (V) (Approx.)
		(+)	(-)		
Front LH	M20	62 (SB)	Ground	OPEN	0
				CLOSE	Battery voltage

OK or NG

- OK >> Door switch is OK.
- NG >> GO TO 2.

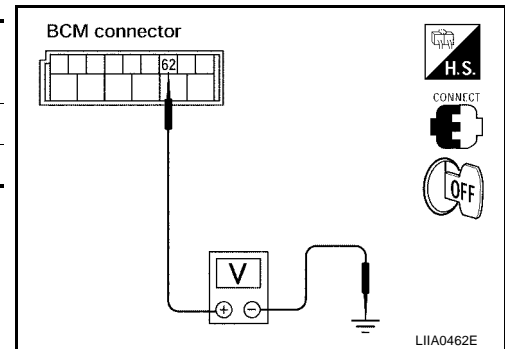

2. CHECK DOOR SWITCH CIRCUIT

1. Turn ignition switch OFF.
2. Disconnect door switch and BCM connector.
3. Check continuity between front door switch LH connector B8 (LH) terminal 2 and BCM connector M18 terminal 62.

Front LH

2 (SB) – 62 (SB) :Continuity should exist.

4. Check continuity between door switch LH connector B8 (LH) terminal 2 and ground.

2 (SB) – Ground :Continuity should not exist.

OK or NG

- OK >> GO TO 3.
- NG >> Repair or replace harness.

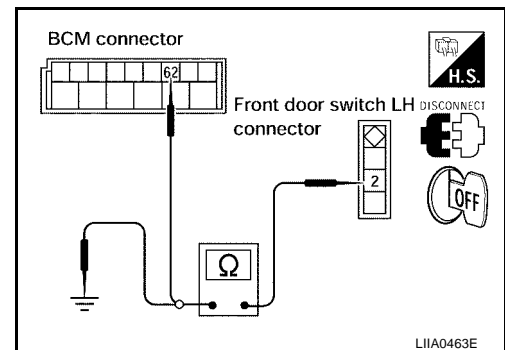

AUTOMATIC DRIVE POSITIONER

3. CHECK DOOR SWITCH

Check continuity between front door switch LH terminal 2 and body ground part of door switch.

Terminal	Door switch	Continuity
2	Pushed	No
	Released	Yes

OK or NG

- OK >> Further inspection is necessary. Refer to symptom chart.
 NG >> Replace malfunction door switch.

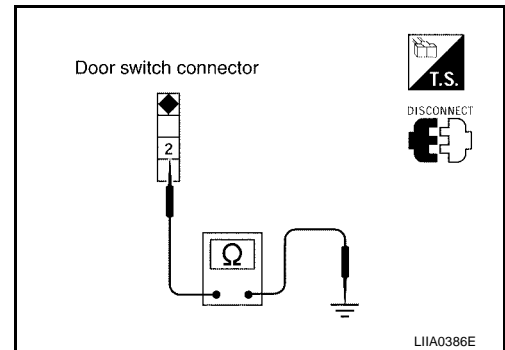

SEAT MEMORY SWITCH CIRCUIT INSPECTION

1. CHECK FUNCTION

With CONSULT-II

With "SET SW, MEMORY SW1, MEMORY SW2", "SET SW" on the DATA MONITOR, operate the switch to check ON/OFF operation.

Monitor item [OPERATION or UNIT]	Contents
MEMORY SW1	"ON/OFF" ON/OFF status judged from the seat memory switch 1 signal is displayed.
MEMORY SW2	"ON/OFF" ON/OFF status judged from the seat memory switch 2 signal is displayed.
SET SW	"ON/OFF" ON/OFF status judged from the setting switch signal is displayed.

DATA MONITOR

MONITOR	
SLIDE SW-FR	OFF
SLIDE SW-RR	OFF
RECLN SW-FR	OFF
RECLN SW-RR	OFF
LIFT FR SW-UP	OFF
LIFT FR SW-DN	OFF
LIFT RR SW-UP	OFF
LIFT RR SW-DN	OFF
SET SW	OFF

Page Down

RECORD

MODE	BACK	LIGHT	COPY
------	------	-------	------

DATA MONITOR

MONITOR	
TELESCO SW-FR	OFF
TELESCO SW-RR	OFF
TILT SW-UP	OFF
TILT SW-DOWN	OFF
MEMORY SW 1	OFF
MEMORY SW 2	OFF
CANCEL SW	OFF
DOOR SW-DR	OFF
VHCL SPEED SE	<7km/

Page Up Page Down

RECORD

MODE	BACK	LIGHT	COPY
------	------	-------	------

PIIA0309E

Without CONSULT-II

GO TO 2.

OK or NG

- OK >> Seat memory switch circuit is OK.
 NG >> GO TO 2.

AUTOMATIC DRIVE POSITIONER

2. CHECK SEAT MEMORY SWITCH

1. Turn ignition switch OFF.
2. Disconnect seat memory switch connector.
3. Operate the setting switch and memory switch.
4. Check continuity between seat memory switch as follows.

Con- nector	Terminal		Condition	Continuity
	(+)	(-)		
D5	3	4	Set switch: ON	Continuity should exist.
			Set switch: OFF	Continuity should not exist.
	2		Memory switch 1 ON	Continuity should exist.
			Memory switch 1: OFF	Continuity should not exist.
			Memory switch 2: ON	Continuity should exist.
			Memory switch 2: OFF	Continuity should not exist.
1				

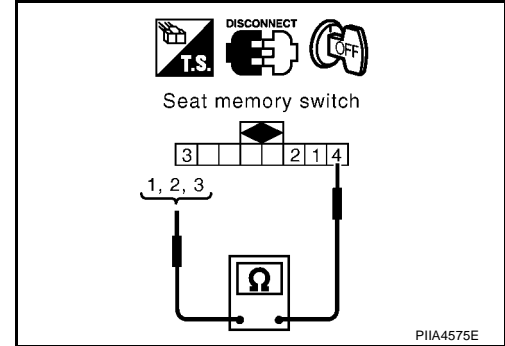

OK or NG

- OK >> GO TO 3.
 NG >> Replace seat memory switch.

3. CHECK HARNESS CONTINUITY

1. Disconnect automatic drive positioner control unit connector.
2. Check continuity between automatic drive positioner control unit connector M41 terminals 9 (L/W), 24 (R/B), 25 (V) and seat memory switch connector D5 terminals 1 (V), 2 (L/W), 3 (R/B).

- 9 (L/W) – 2 (L/W) : Continuity should exist.**
24 (R/B) – 3 (R/B) : Continuity should exist.
25 (V) – 1 (V) : Continuity should exist.

3. Check continuity between automatic drive positioner control unit connector M41 terminals 9 (L/W), 24 (R/B), 25 (V) and ground.

- 9 (L/W) – Ground : Continuity should not exist.**
24 (R/B) – Ground : Continuity should not exist.
25 (V) – Ground : Continuity should not exist.

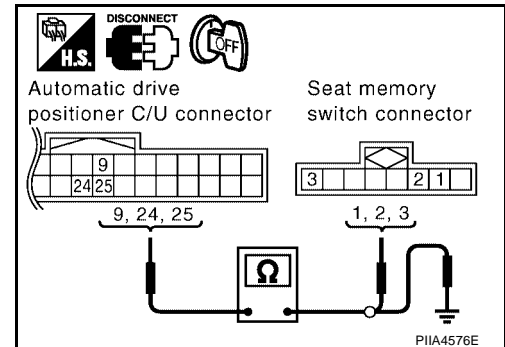

OK or NG

- OK >> GO TO 4.
 NG >> Repair or replace harness between automatic drive positioner control unit and seat memory switch.

4. CHECK SEAT MEMORY SWITCH GROUND CIRCUIT

Check continuity between seat memory switch D5 terminal 4 (B) and ground.

- 4 (B) – Ground : Continuity should exist.**

OK or NG

- OK >> Replace automatic drive positioner control unit.
 NG >> Repair or replace harness between seat memory switch and ground.

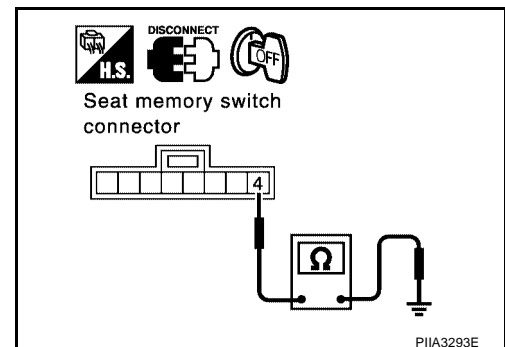

AUTOMATIC DRIVE POSITIONER

SLIDING SWITCH CIRCUIT INSPECTION

1. CHECK FUNCTION

④ With CONSULT-II

With "SLIDE SW-FR, SLIDE SW-RR" on the DATA MONITOR, operate the sliding switch to check ON/OFF operation.

Monitor item [OPERATION or UNIT]		Contents
SLIDE SW-FR	"ON/OFF"	ON / OFF status judged from the sliding switch (FR) signal is displayed.
SLIDE SW-RR	"ON/OFF"	ON / OFF status judged from the sliding switch (RR) signal is displayed.

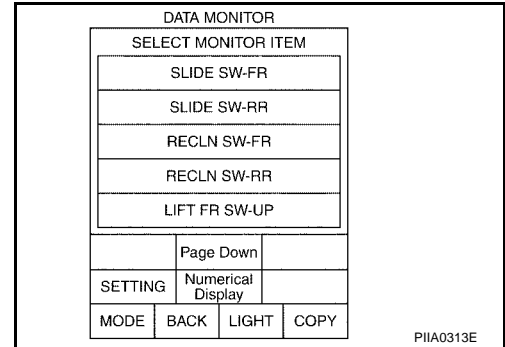

⊗ Without CONSULT-II

- Turn ignition switch OFF.
- Check voltage between driver seat control unit connector and ground.

Connector	Terminal (Wire color)		Condition	Voltage (V) (Approx)
	(+)	(-)		
P2	11 (GR/R)	Ground	Sliding switch ON(RR operation)	0
			Sliding switch OFF	Battery voltage
	26 (P/B)		Sliding switch ON(FR operation)	0
			Sliding switch OFF	Battery voltage

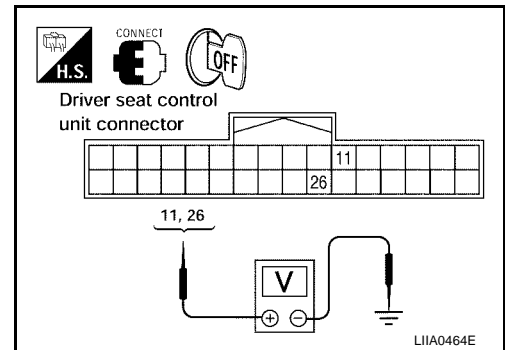

OK or NG

- OK >> Sliding switch circuit is OK.
 NG >> GO TO 2.

2. CHECK POWER SEAT SWITCH HARNESS CONTINUITY

- Disconnect driver seat control unit connector and power seat switch connector.
- Check continuity between driver seat control unit connector P2 terminals 11 (GR/R), 26 (P/B) and power seat switch connector P8 terminals 1 (P/B), 2 (GR/R).

11 (GR/R) – 2 (GR/T) : Continuity should exist.
26 (P/B) – 1 (P/B) : Continuity should exist.

- Check continuity between driver seat control unit connector P2 terminals 11 (GR/R), 26 (P/B) and ground.

11 (GR/R) – Ground : Continuity should not exist.
26 (P/B) – Ground : Continuity should not exist.

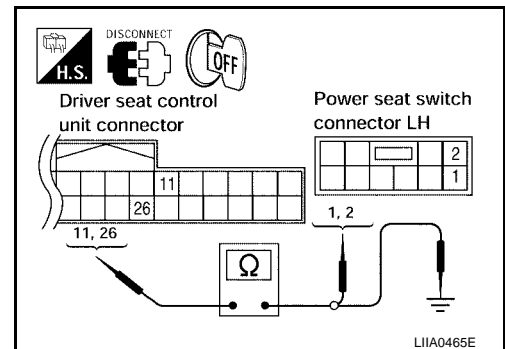

OK or NG

- OK >> GO TO 3.
 NG >> Repair or replace harness between driver seat control unit and power seat switch.

AUTOMATIC DRIVE POSITIONER

3. CHECK SLIDING SWITCH

Check continuity between power seat switch as follows.

Connector	Terminal		Condition	Continuity
	(+)	(-)		
P8	1	9	Sliding switch ON (RR operation)	Yes
			Sliding switch OFF	No
	2		Sliding switch ON (FR operation)	Yes
			Sliding switch OFF	No

OK or NG

- OK >> Check the condition of the harness and connector.
- NG >> Replace power seat switch.

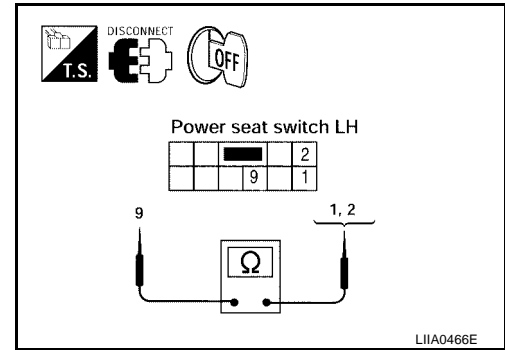

RECLINING SWITCH INSPECTION

1. CHECK FUNCTION

With CONSULT-II

With "RECLINING SW-FR, RECLINING SW-RR" on the DATA MONITOR, operate the reclining switch to check ON/OFF operation.

Monitor item [OPERATION or UNIT]	Contents	
RECLN SW-FR	"ON/OFF"	ON/OFF status judged from the reclining switch (FR) signal is displayed.
RECLIN SW-RR	"ON/OFF"	ON/OFF status judged from the reclining switch (RR) signal is displayed.

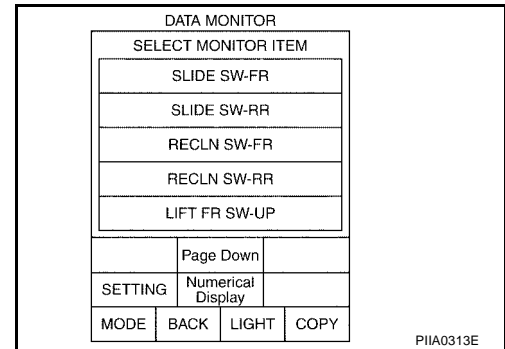

Without CONSULT-II

1. Turn ignition switch OFF.
2. Check voltage between driver seat control unit connector and ground.

Connector	Terminals (Wire color)		Condition	Voltage (V) (Approx)
	(+)	(-)		
P2	12 (P)	Ground	Reclining switch ON (RR operation)	0
			Reclining switch OFF	Battery voltage
	27 (W/R)		Reclining switch ON (FR operation)	0
			Reclining switch OFF	Battery voltage

OK or NG

- OK >> Reclining switch circuit is OK.
- NG >> GO TO 2.

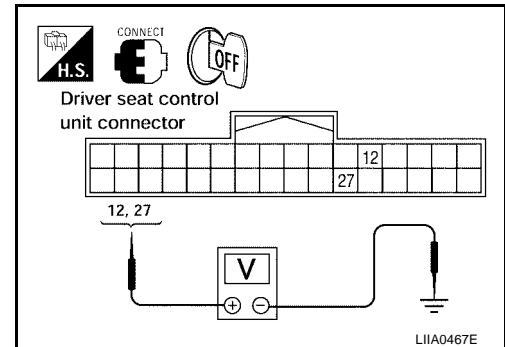

AUTOMATIC DRIVE POSITIONER

2. CHECK HARNESS CONTINUITY

1. Disconnect driver seat control unit connector and power seat switch connector.
2. Check continuity between driver seat control unit connector P2 terminals 12 (P), 27 (W/R) and power seat switch connector P8 terminals 3 (W/R), 4 (P).

12 (P) – 4 (P) : Continuity should exist.
27 (W/R) – 3 (W/R) : Continuity should exist.

3. Check continuity between driver seat control unit connector P2 terminals 12 (P), 27 (W/R) and ground.

12 (P) – Ground : Continuity should not exist.
27 (W/R) – Ground : Continuity should not exist.

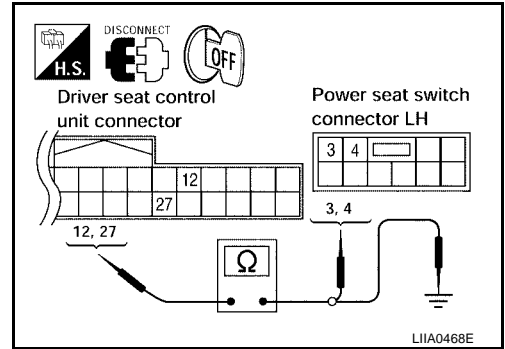

OK or NG

OK >> GO TO 3.

NG >> Repair or replace harness between driver seat control unit and power seat switch.

3. RECLINING SWITCH INSPECTION

Check continuity between driver seat switch as follows.

Connector	Terminal		Condition	Continuity
	(+)	(-)		
P8	4	9	Reclining switch ON (RR operation)	Yes
			Reclining switch OFF	No
	3		Reclining switch ON (FR operation)	Yes
			Reclining switch OFF	No

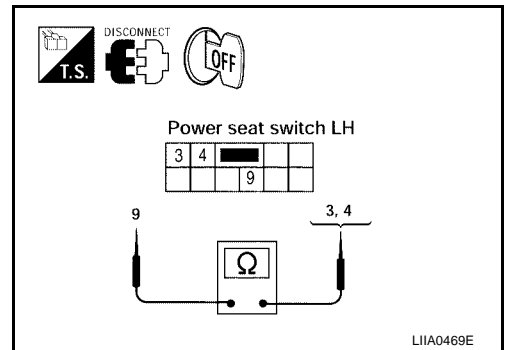

OK or NG

OK >> Check the condition of the harness and connector.

NG >> Replace power seat switch.

AUTOMATIC DRIVE POSITIONER

FRONT LIFTING SWITCH CIRCUIT INSPECTION

1. CHECK FUNCTION

④ With CONSULT-II

With "LIFT FR SW-UP, LIFT FR SW-DN" on the DATA MONITOR, operate the front lifting switch to check ON/OFF operation.

Monitor item [OPERATION or UNIT]		Contents
LIFT FR SW-DN	"ON/OFF"	ON / OFF status judged from the FR lifter switch (DOWN) signal is displayed.
LIFT RR SW-UP	"ON/OFF"	ON / OFF status judged from the RR lifter switch (UP) signal is displayed.

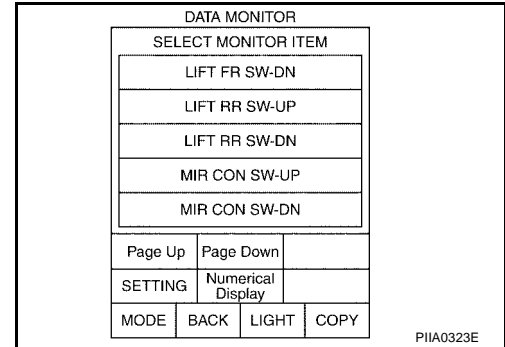

⊗ Without CONSULT-II

1. Turn ignition switch OFF.
2. Check voltage between driver seat control unit P2 and ground.

Connector	Terminals (Wire color)		Condition	Voltage (V) (Approx)
	(+)	(-)		
P2	13 (W)	Ground	Front lifting switch ON (DOWN operation)	0
			Front lifting switch OFF	Battery voltage
	28 (BR)		Front lifting switch ON (UP operation)	0
			Front lifting switch OFF	Battery voltage

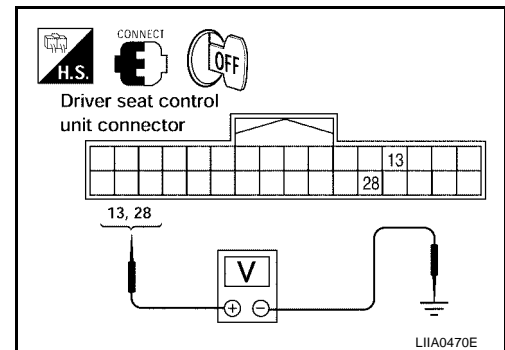

OK or NG

- OK >> Front lifting switch circuit is OK.
 NG >> GO TO 2.

2. CHECK POWER SEAT SWITCH HARNESS CONTINUITY

1. Disconnect driver seat control unit connector and power seat switch connector.
2. Check continuity between driver seat control unit connector P2 terminals 13 (W), 28 (BR) and driver seat switch connector P8 terminals 5 (BR), 6 (W).

13 (W) – 6 (W) : Continuity should exist.

28 (BR) – 5 (BR) : Continuity should exist.

3. Check continuity between driver seat control unit connector P2 terminals 13 (OR/B), 28 (L/R) and ground

13 (W) – Ground : Continuity should not exist.

28 (BR) – Ground : Continuity should not exist.

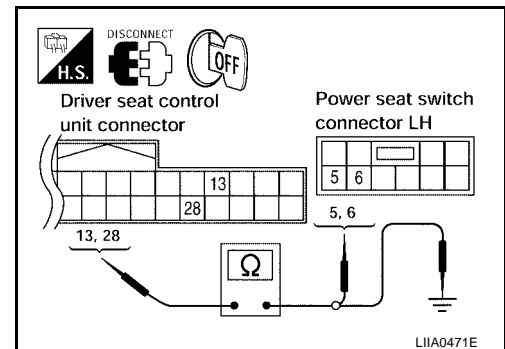

OK or NG

- OK >> GO TO 3.
 NG >> Repair or replace harness between driver seat control unit and power seat switch.

AUTOMATIC DRIVE POSITIONER

3. CHECK FRONT LIFTING SWITCH

Check continuity between driver seat switch as follows.

Connector	Terminals		Condition	Continuity
	(+)	(-)		
B305	13	32A	Front lifting switch ON (DOWN operation)	Yes
			Front lifting switch OFF	No
	28		Front lifting switch ON (UP operation)	Yes
			Front lifting switch OFF	No

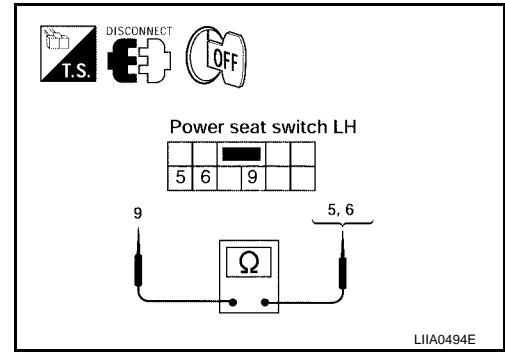

OK or NG

- OK >> Check the harness and connector.
- NG >> Replace power seat switch (driver side).

REAR LIFTING SWITCH CIRCUIT INSPECTION

1. CHECK FUNCTION

With CONSULT-II

With "LIFT RR SW-UP, LIFT RR SW-DN" on the DATA MONITOR, operate the rear lifting switch to check ON/OFF operation.

Monitor item [OPERATION or UNIT]		Contents
LIFT RR SW-UP	"ON/OFF"	Operation (ON)/open (OFF) status judged from the RR lifter switch (UP) signal is displayed.
LIFT RR SW-DN	"ON/OFF"	Operation (ON)/open (OFF) status judged from the RR lifter switch (DOWN) signal is displayed.

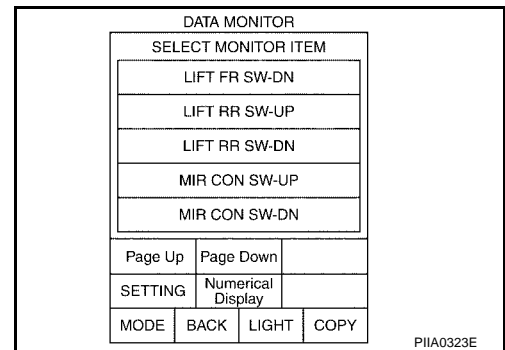

Without CONSULT-II

1. Turn ignition switch OFF.
2. Check voltage between driver seat control unit connector and ground.

Connector	Terminals (Wire color)		Condition	Voltage (V) (Approx)
	(+)	(-)		
P2	14 (GR)	Ground	Rear lifting switch ON (DOWN operation)	0
			Rear lifting switch OFF	Battery voltage
	29 (Y/R)		Rear lifting switch ON (UP operation)	0
			Rear lifting switch OFF	Battery voltage

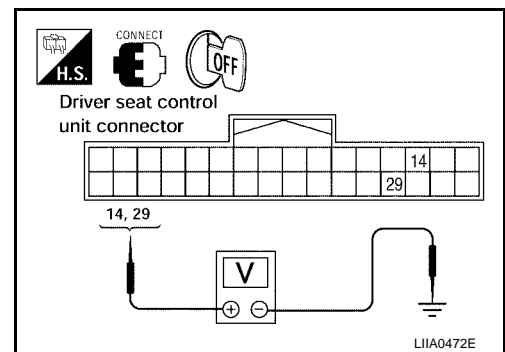

OK or NG

- OK >> Rear end seat lifting switch circuit is OK.
- NG >> GO TO 2.

AUTOMATIC DRIVE POSITIONER

2. CHECK POWER SEAT SWITCH HARNESS CONTINUITY

1. Disconnect driver seat control unit connector and power seat switch connector.
2. Check continuity between driver seat control unit connector P2 terminals 14 (GR), 29 (Y/R) and power seat switch connector P8 terminals 7 (Y/R), 8 (GR).

14 (GR) – 8 (GR) : Continuity should exist.
29 (Y/R) – 7 (Y/R) : Continuity should exist.

3. Check continuity between driver seat control unit connector P2 terminals 14 (GR), 29 (Y/R) and ground.

14 (Y/R) – Ground : Continuity should not exist.
29 (W/G) – Ground : Continuity should not exist.

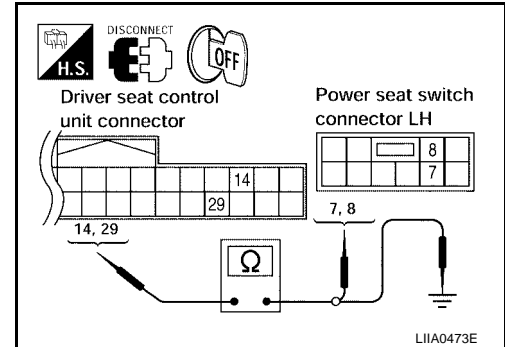

OK or NG

- OK >> GO TO 3.
 NG >> Repair or replace harness between driver seat control unit and power seat switch.

3. CHECK REAR LIFTING SWITCH

Check continuity between driver seat switch as follows.

Connector	Terminals		Condition	Continuity
	(+)	(-)		
P8	8	9	Rear lifting switch ON (DOWN operation)	Yes
			Rear lifting switch OFF	No
	7		Rear lifting switch ON (UP operation)	Yes
			Rear lifting switch OFF	No

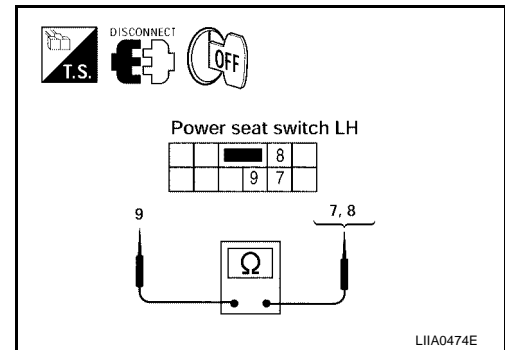

OK or NG

- OK >> Check the condition of the harness and connector.
 NG >> Replace power seat switch.

POWER SEAT SWITCH GROUND INSPECTION

1. CHECK POWER SEAT SWITCH GROUND CIRCUIT

Check continuity between power seat switch connector P8 terminal 9 (B/W) and ground.

9 (B/W) – Ground : Continuity should exist.

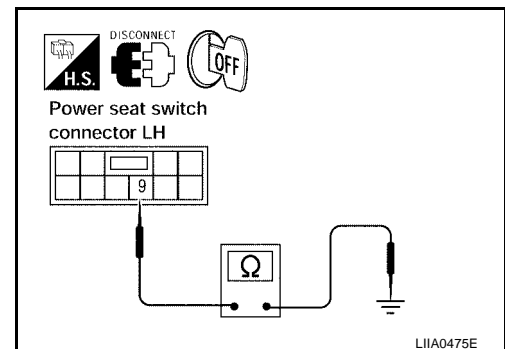

OK or NG

- OK >> Check the condition of the harness and connector.
 NG >> Repair or replace harness between power seat switch and ground.

AUTOMATIC DRIVE POSITIONER

DOOR MIRROR REMOTE CONTROL SWITCH (CHANGEOVER SWITCH) CIRCUIT CHECK

1. CHECK FUNCTION

Ⓜ With CONSULT-II

Check operation with "MIR CHNG SW - R, MIR CHNG SW - L" on the DATA MONITOR to make sure pulse changes.

Monitor item [OPERATION or UNIT]		
"MIR CHNG SW - R"	"ON/OFF"	ON/OFF status judged from the door mirror remote control switch (switching to RIGHT) signal is displayed.
MIR CHNG SW - L	"ON/OFF"	ON/OFF status judged from the door mirror remote control switch (switching to LEFT) signal is displayed.

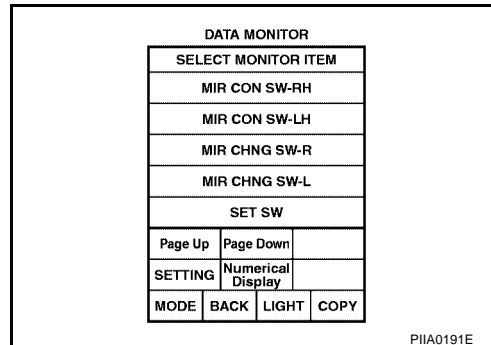

⊗ Without CONSULT-II

1. Turn ignition switch ACC.
2. Check voltage between automatic drive positioner control unit connector and ground.

Connector	Terminals (Wire color)		Condition	Voltage (V) (Approx.)
	(+)	(-)		
M41	2 (LG/R)	Ground	Changeover switch RIGHT position	0
			Changeover switch neutral position	5
	18 (L/R)		Changeover switch LEFT position	0
			Changeover switch neutral position	5

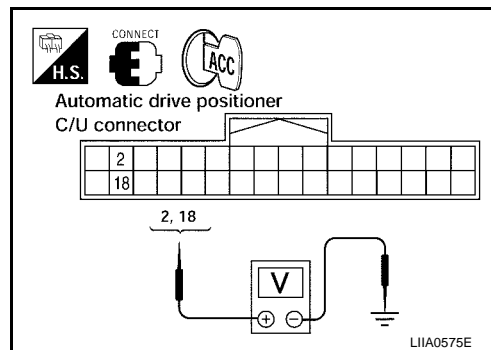

OK or NG

- OK >> Door mirror remote control switch (changeover switch) circuit is OK.
 NG >> GO TO 2.

AUTOMATIC DRIVE POSITIONER

2. CHECK DOOR MIRROR REMOTE CONTROL SWITCH CIRCUIT HARNESS CONTINUITY

1. Turn ignition switch OFF.
2. Disconnect automatic drive positioner control unit connector and door mirror LH connector.
3. Check continuity between automatic drive positioner control unit connector M41 terminals 2 (LG/R), 18 (L/R) and door mirror LH connector D4 terminals 5 (LG/R), 6 (L/R).

2 (LG/R) – 5 (LG/R) : Continuity should exist.

18 (L/R) – 6 (L/R) : Continuity should exist.

4. Check continuity between driver seat control unit connector M41 terminals 2 (LG/R), 18 (L/R) and ground.

2 (LG/R) – Ground : Continuity should not exist.

18 (L/R) – Ground : Continuity should not exist.

OK or NG

OK >> GO TO 3.

NG >> Repair or replace harness between automatic drive positioner control unit and door mirror LH.

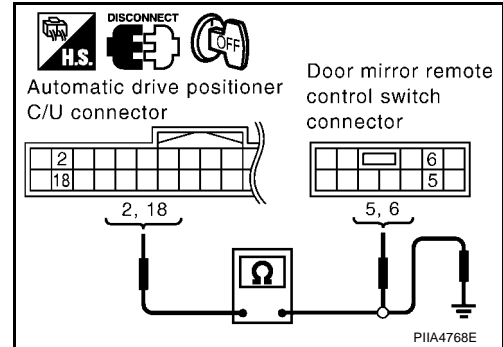

3. CHECK DOOR MIRROR REMOTE CONTROL SWITCH (CHANGEOVER SWITCH)

Check voltage between automatic drive positioner control unit as follows.

Connector	Terminals (Wire color)		Condition	Continuity
	(+)	(-)		
M6	5	7	Changeover switch RIGHT position	YES
			Changeover switch neutral position	NO
	6		Changeover switch LEFT position	YES
			Changeover switch neutral position	NO

OK or NG

OK >> Check the condition of the harness and the connector.

NG >> Replace door mirror remote control switch.

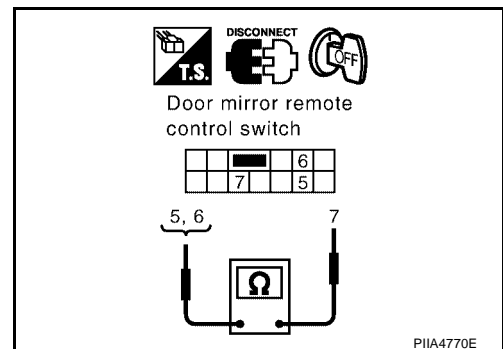

AUTOMATIC DRIVE POSITIONER

DOOR MIRROR REMOTE CONTROL SWITCH (MIRROR SWITCH) CIRCUIT CHECK

1. CHECK FUNCTION

④ With CONSULT-II

Check operation with "MIR CON SW-UP/DN, MIR CON SW-RH/LH" on the DATA MONITOR to make sure pulse changes.

Monitor item [OPERATION or UNIT]		
MIR CON SW-UP	"ON/OFF"	ON/OFF status judged from the door mirror remote control switch (UP) signal is displayed.
MIR CON SW-DN	"ON/OFF"	ON/OFF status judged from the door mirror remote control switch (DOWN) signal is displayed.
MIR CON SW-RH	"ON/OFF"	ON/OFF status judged from the door mirror remote control switch (RIGHT) signal is displayed.
MIR CON SW-LH	"ON/OFF"	ON/OFF status judged from the door mirror remote control switch (LEFT) signal is displayed.

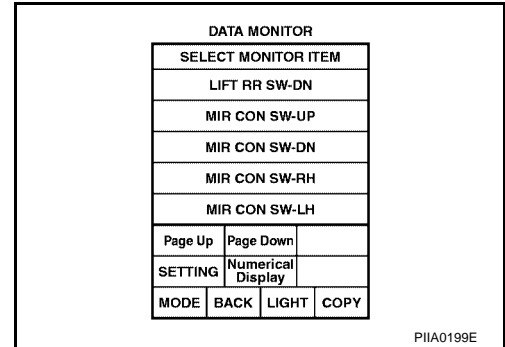

⊗ Without CONSULT-II

1. Turn ignition switch ACC.
2. Check voltage between automatic drive positioner control unit connector and ground.

Connector	Terminals (Wire color)		Condition	Voltage (V) (Approx.)
	(+)	(-)		
M41	3 (Y/B)	Ground	Mirror switch UP operation	0
			Mirror switch neutral operation	5
	4 (V/W)	Ground	Mirror switch LEFT operation	0
			Mirror switch neutral operation	5
	19 (L/B)	Ground	Mirror switch DOWN operation	0
			Mirror switch neutral operation	5
	20 (BR/Y)	Ground	Mirror switch RIGHT operation	0
			Mirror switch neutral operation	5

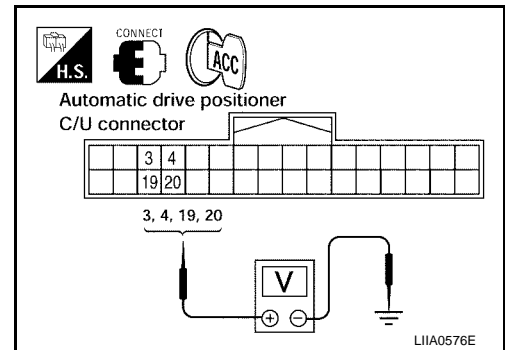

OK or NG

- OK >> Door mirror remote control switch (mirror switch) circuit is OK.
- NG >> GO TO 2.

AUTOMATIC DRIVE POSITIONER

2. CHECK DOOR MIRROR REMOTE CONTROL SWITCH CIRCUIT HARNESS CONTINUITY

1. Turn ignition switch OFF.
2. Disconnect automatic drive positioner control unit connector and door mirror remote control switch connector.
3. Check continuity between automatic drive positioner control unit connector M41 terminals 3 (Y/B), 4 (V/W), 19 (L/B), 20 (BR/Y) and door mirror remote control switch connector m6 terminals 1 (BR/Y), 2 (V/W), 3 (Y/B), 4 (L/B).

- 3 (Y/B) – 3 (Y/B) : Continuity should exist.**
4 (V/W) – 2 (V/W) : Continuity should exist.
19 (L/B) – 4 (L/B) : Continuity should exist.
20 (BR/Y) – 1 (BR/Y) : Continuity should exist.

4. Check continuity between driver seat control unit connector M41 terminals 3 (Y/B), 4 (V/W), 19 (L/B), 20 (BR/Y) and ground.

- 3 (Y/B) – Ground : Continuity should not exist.**
4 (V/W) – Ground : Continuity should not exist.
19 (L/B) – Ground : Continuity should not exist.
20 (BR/Y) – Ground : Continuity should not exist.

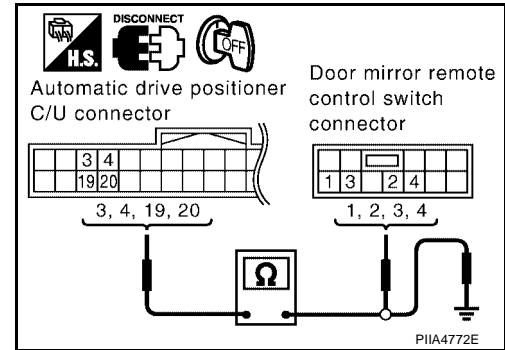

OK or NG

OK >> GO TO 3.

NG >> Repair or replace harness between automatic drive positioner control unit and door mirror remote control switch.

3. CHECK DOOR MIRROR REMOTE CONTROL SWITCH (MIRROR SWITCH)

Check continuity between door mirror remote control switch as follows.

Connector	Terminals (Wire color)		Condition	Continuity
	(+)	(-)		
M6	1	7	Mirror switch RIGHT operation	YES
			Mirror switch neutral operation	NO
	2		Mirror switch LEFT operation	YES
			Mirror switch neutral operation	NO
	3		Mirror switch UP operation	YES
			Mirror switch neutral operation	NO
	4		Mirror switch DOWN operation	YES
			Mirror switch neutral operation	NO

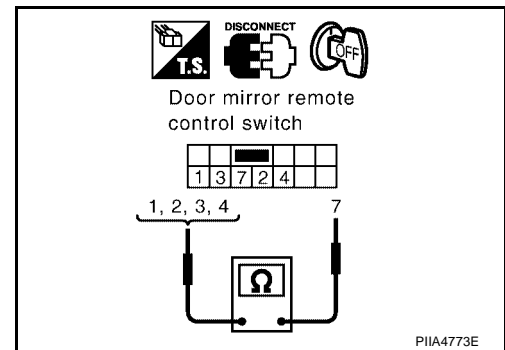

OK or NG

OK >> Check the condition of the harness and the connector.

NG >> Replace door mirror remote control switch.

AUTOMATIC DRIVE POSITIONER

DOOR MIRROR REMOTE CONTROL SWITCH GROUND CIRCUIT CHECK

1. CHECK DOOR MIRROR REMOTE CONTROL SWITCH GROUND CIRCUIT

Check continuity between door mirror remote control switch connector M6 terminal 7 (B) and ground.

7 (B) – Ground : Continuity should exist.

OK or NG

- OK >> GO TO 2.
- NG >> Repair or replace harness between door mirror remote control switch and ground.

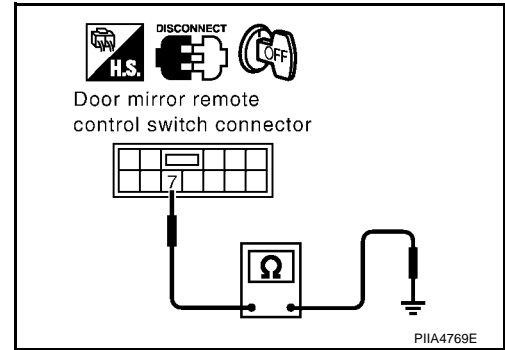

2. CHECK DOOR MIRROR REMOTE CONTROL SWITCH GROUND CIRCUIT

Check continuity between door mirror remote control switch as follows.

Connector	Terminals (Wire color)		Condition	Continuity
	(+)	(-)		
M6	5	7	Changeover switch RIGHT position	YES
			Changeover switch neutral position	NO
	6		Changeover switch LEFT position	YES
			Changeover switch neutral position	NO

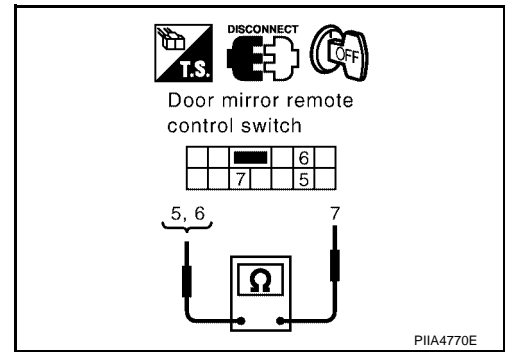

OK or NG

- OK >> Check the condition of the harness and the connector.
- NG >> Replace door mirror remote control switch.

AUTOMATIC DRIVE POSITIONER

STEERING WHEEL TELESCOPIC SWITCH CIRCUIT INSPECTION

1. CHECK FUNCTION

④ With CONSULT-II

With "TELESCO SW-FR, TELESCO SW-RR" on the DATA MONITOR, operate the ADP steering wheel telescopic switch to check ON/OFF operation.

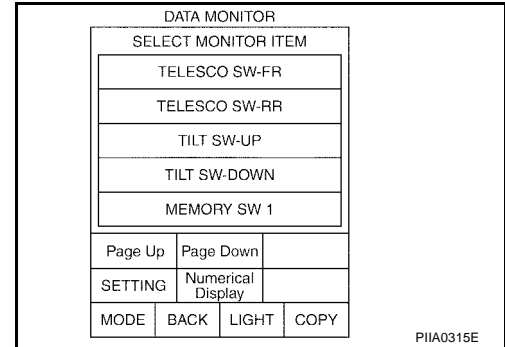

Monitor item [OPERATION or UNIT]		Contents
TELESCO SW-FR	"ON/OFF"	Operation (ON)/open (OFF) status judged from the telescopic switch (FR) signal is displayed.
TELESCO SW-RR	"ON/OFF"	Operation (ON)/open (OFF) status judged from the telescopic switch (RR) signal is displayed.

⊗ Without CONSULT-II

- Turn ignition switch OFF.
- Check voltage between automatic drive positioner control unit connector and ground.

Connector	Terminals (Wire color)		Condition	Voltage (V) (Approx)
	(+)	(-)		
M41	11 (P/L)	Ground	Telescopic switch ON (RR operation)	0
			Telescopic switch OFF	5
	27 (G/W)		Telescopic switch ON (FR operation)	0
			Telescopic switch OFF	5

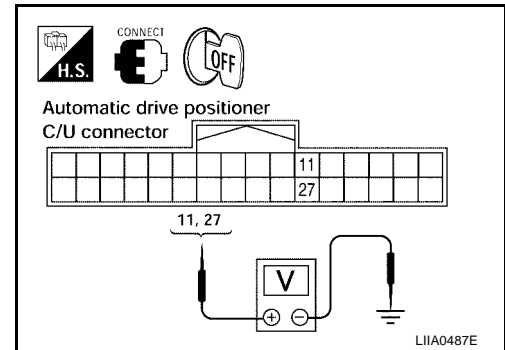

OK or NG

- OK >> ADP steering wheel telescopic switch circuit is OK.
- NG >> GO TO 2.

2. CHECK ADP STEERING WHEEL TELESCOPIC SWITCH HARNESS CONTINUITY

- Disconnect automatic drive positioner control unit connector and ADP steering wheel telescopic switch connector.
- Check continuity between automatic drive positioner control unit connector M41 terminals 11 (P/L), 27 (G/W) and ADP steering wheel telescopic switch connector M16 terminals 4 (G/W), 5 (P/L).

11 (P/L) – 5 (P/L) : Continuity should exist.
27 (G/W) – 4 (G/W) : Continuity should exist.

- Check continuity between automatic drive positioner control unit connector M41 terminals 11 (P/L), 27 (G/W) and ground.

11 (P/L) – Ground : Continuity should not exist.
27 (G/W) – Ground : Continuity should not exist.

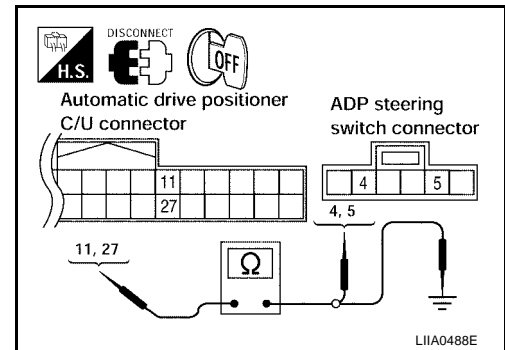

OK or NG

- OK >> GO TO 3.
- NG >> Repair or replace harness between automatic drive positioner control unit and ADP steering wheel telescopic switch.

AUTOMATIC DRIVE POSITIONER

3. CHECK ADP STEERING WHEEL TELESCOPIC SWITCH

Check continuity between ADP steering wheel telescopic switch as follows.

Connector	Terminals		Condition	Continuity
	(+)	(-)		
M16	4	1	Telescopic switch ON (RR operation)	Yes
			Telescopic switch OFF	No
	5		Telescopic switch ON (FR operation)	Yes
			Telescopic switch OFF	No

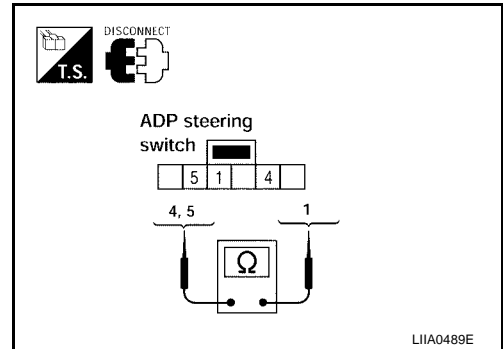

OK or NG

OK >> GO TO 4.

NG >> Replace ADP steering wheel telescopic switch.

4. CHECK ADP STEERING WHEEL TELESCOPIC SWITCH GROUND CIRCUIT

Check continuity between ADP steering wheel telescopic switch connector M16 terminal 1 (B) and ground.

1 (B) – Ground : Continuity should exist.

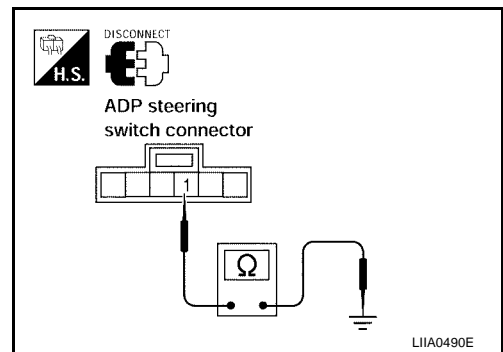

OK or NG

OK >> Check the condition of the harness and connector.

NG >> Replace or replace harness between ADP steering wheel telescopic switch and ground.

AUTOMATIC DRIVE POSITIONER

STEERING WHEEL TILT SWITCH CIRCUIT INSPECTION

1. CHECK FUNCTION

④ With CONSULT-II

With "TILT SW-UP, TILT SW-DOWN" on the DATA MONITOR, operate the ADP steering wheel tilt switch to check ON/OFF operation.

Monitor item [OPERATION or UNIT]		Contents
TILT SW-UP	"ON/OFF"	Operation (ON)/open (OFF) status judged from the tilt switch (FR) signal is displayed.
TILT SW-DOWN	"ON/OFF"	Operation (ON)/open (OFF) status judged from the tilt switch (RR) signal is displayed.

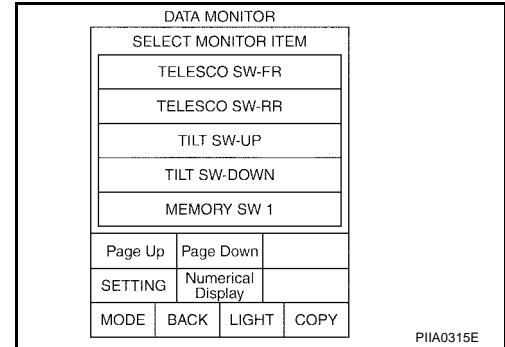

⊗ Without CONSULT-II

- Turn ignition switch OFF.
- Check voltage between automatic drive positioner control unit connector and ground.

Connector	Terminals (Wire color)		Condition	Voltage (V) (Approx)
	(+)	(-)		
M41	1 (Y/G)	Ground	Tilt switch ON (UP operation)	0
			Tilt switch OFF	5
	17 (LG/B)		Tilt switch ON (DOWN operation)	0
			Tilt switch OFF	5

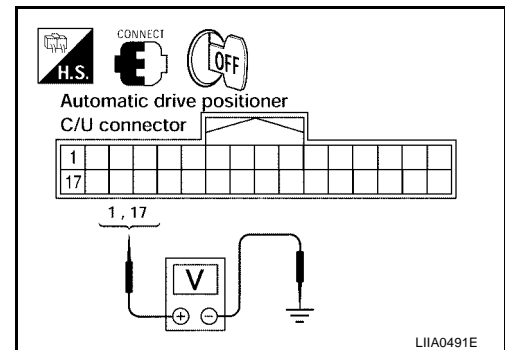

OK or NG

- OK >> ADP steering wheel tilt switch circuit is OK.
 NG >> GO TO 2.

2. CHECK ADP STEERING WHEEL TILT SWITCH HARNESS CONTINUITY

- Disconnect automatic drive positioner control unit connector and ADP steering wheel tilt switch connector.
- Check continuity between automatic drive positioner control unit connector M41 terminals 1 (Y/G), 17 (LG/B) and ADP steering wheel tilt switch connector M16 terminals 2 (Y/G), 3 (LG/B).

1 (Y/G) – 2 (Y/G) : Continuity should exist.

17 (LG/B) – 3 (LG/B) : Continuity should exist.

- Check continuity between automatic drive positioner control unit connector M41 terminals 1 (P/L), 17 (LG/B) and ground.

1 (Y/G) – Ground : Continuity should not exist.

17 (LG/B) – Ground : Continuity should not exist.

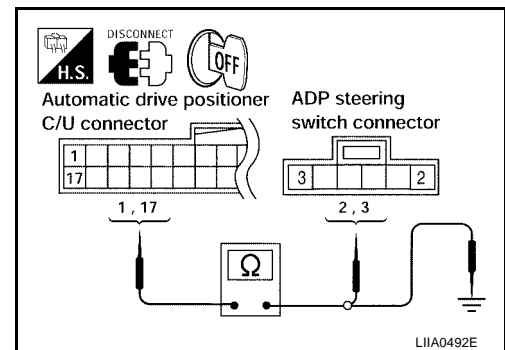

OK or NG

- OK >> GO TO 3.
 NG >> Repair or replace harness between automatic drive positioner control unit and ADP steering wheel tilt switch.

AUTOMATIC DRIVE POSITIONER

3. CHECK ADP STEERING WHEEL TILT SWITCH

Check continuity between ADP steering wheel tilt switch as follows.

Connector	Terminals		Condition	Continuity
	(+)	(-)		
M16	2	1	Tilt switch ON (UP operation)	Yes
			Tilt switch OFF	No
	3		Tilt switch ON (DOWN operation)	Yes
			Tilt switch OFF	No

OK or NG

OK >> GO TO 4.

NG >> Replace ADP steering wheel tilt switch.

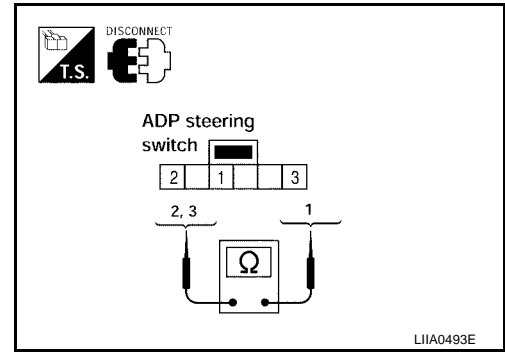

4. CHECK ADP STEERING WHEEL TILT SWITCH GROUND CIRCUIT

Check continuity between ADP steering wheel tilt switch connector M16 terminal 1 (B) and ground.

1 (B) – Ground : Continuity should exist.

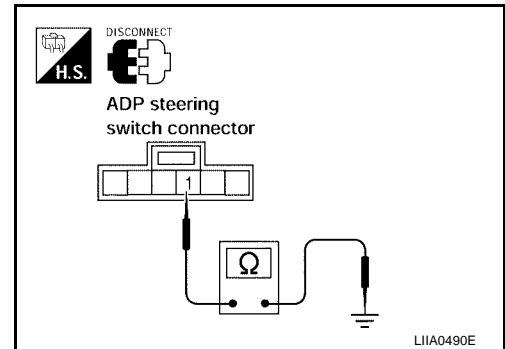

OK or NG

OK >> Check the condition of the harness and connector.

NG >> Replace or replace harness between ADP steering wheel tilt switch and ground.

SEAT MEMORY INDICATOR LAMP CIRCUIT INSPECTION

1. CHECK FUNCTION

With CONSULT-II

With "MEMORY SW INDCTR" in ACTIVE TEST, check operation.

Test item	Description
MEMORY SW INDCTR	The memory switch indicator is lit by receiving the drive signal.

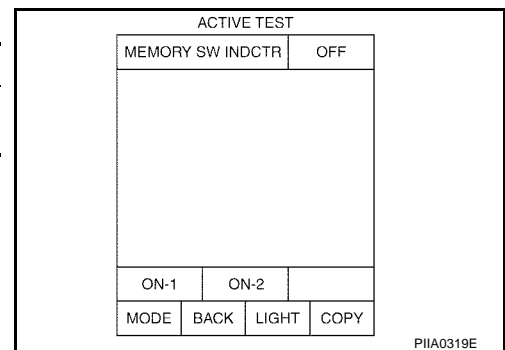

Without CONSULT-II

GO TO 2.

OK or NG

OK >> Seat memory indicator lamp circuit is OK.

NG >> GO TO 2.

AUTOMATIC DRIVE POSITIONER

2. CHECK SEAT MEMORY SWITCH POWER SUPPLY CIRCUIT

1. Turn ignition switch OFF.
2. Disconnect seat memory switch connector.
3. Check voltage between seat memory switch connector D5 terminal 5 (Y/R) and ground.

5 (Y/R) – Ground : Battery voltage

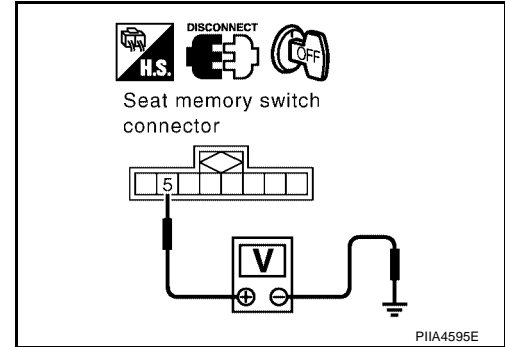

OK or NG

OK >> GO TO 3.

NG >> Repair or replace harness between fuse block (J/B) and seat memory switch.

3. CHECK HARNESS CONTINUITY

1. Disconnect automatic drive positioner control unit connector.
2. Check continuity between automatic drive positioner control unit connector M41 terminals 12 (OR), 13 (P) and seat memory switch connector D5 terminals 6 (OR), 7 (P).

12 (OR) – 6 (OR) : Continuity should exist.

13 (P) – 7 (P) : Continuity should exist.

3. Check continuity between automatic drive positioner control unit connector M41 terminals 12 (GR/L), 13 (Y/G) and ground.

12 (OR) – Ground : Continuity should not exist.

13 (P) – Ground : Continuity should not exist.

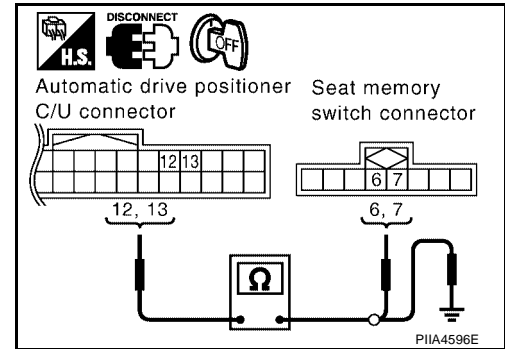

OK or NG

OK >> GO TO 4.

NG >> Repair or replace harness between automatic drive positioner control unit and memory switch.

4. CHECK SEAT MEMORY SWITCH INDICATOR SIGNAL

1. Connect seat memory switch connector.
2. Check voltage between automatic drive positioner control unit connector M41 terminals 12 (GR/L), 13 (Y/G) and ground.

12 (OR) – Ground : Battery voltage

13 (P) – Ground : Battery voltage

OK or NG

OK >> Replace automatic drive positioner control unit.

NG >> Replace seat memory switch.

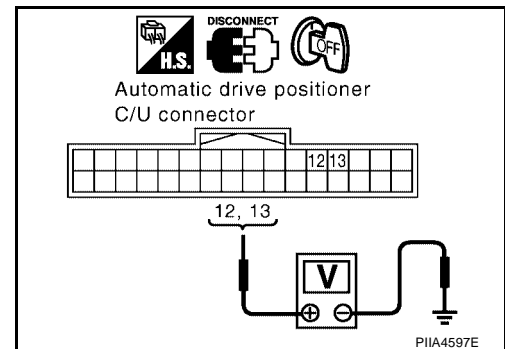

AUTOMATIC DRIVE POSITIONER

UART COMMUNICATION LINE CIRCUIT INSPECTION

1. CHECK UART LINE HERNESS

1. Turn ignition switch OFF.
2. Disconnect driver seat control unit connector and automatic drive positioner control unit connector.
3. Check continuity between driver seat control unit connector P2 terminal 1 (W/B), 17 (GR) and automatic drive positioner connector M41 terminal 10 (R), 26 (R/W).

1 (W/B) – 10 (R) : Continuity should exist.

17 (GR) – 26 (R/W) : Continuity should exist.

4. Check continuity between driver seat control unit connector P2 terminal 1 (W/B), 17 (GR) and ground.

1 (W/B) – Ground : Continuity should not exist.

17 (GR) – Ground : Continuity should not exist.

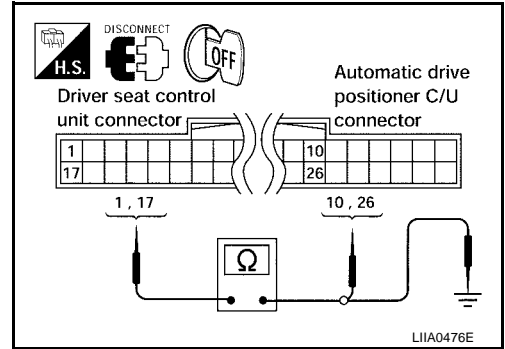

OK or NG

OK >> GO TO 2.

NG >> Repair or replace harness between driver seat control unit and automatic drive positioner control unit.

2. CHECK UART LINE INPUT/OUTPUT SIGNAL 1

Check signal between driver seat control unit connector and ground, with oscilloscope.

Connector	Terminals (Wire color)		Condition	Signal
	(+)	(-)		
P2	17 (GR)	Ground	Seat memory switch ON (1 or 2 operation)	<p style="text-align: right;">PIIA4814E</p>

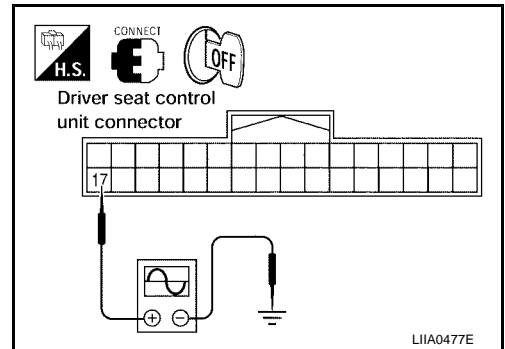

OK or NG

OK >> GO TO 3.

NG >> Replace driver seat control unit.

3. CHECK UART LINE INPUT/OUTPUT SIGNAL 2

Check signal between automatic driver positioner control unit connector ground, with oscilloscope.

Connector	Terminals (Wire color)		Condition	Signal
	(+)	(-)		
M41	10 (R)	Ground	Seat memory switch ON (1 or 2 operation)	<p style="text-align: right;">PIIA4813E</p>

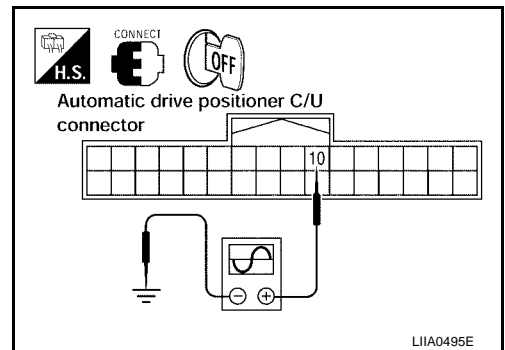

AUTOMATIC DRIVE POSITIONER

OK or NG

- OK >> GO TO 4.
- NG >> Replace automatic driver positioner control unit.

4. CHECK DRIVER SEAT CONTROL UNIT

Dose the automatic drive positioner, when the driver control unit exchanged?

OK or NG

- OK >> Replace automatic drive positioner control unit.
- NG >> Replace driver seat control unit.

POWER SEAT

POWER SEAT

PFP:87016

Schematic

EIS00102

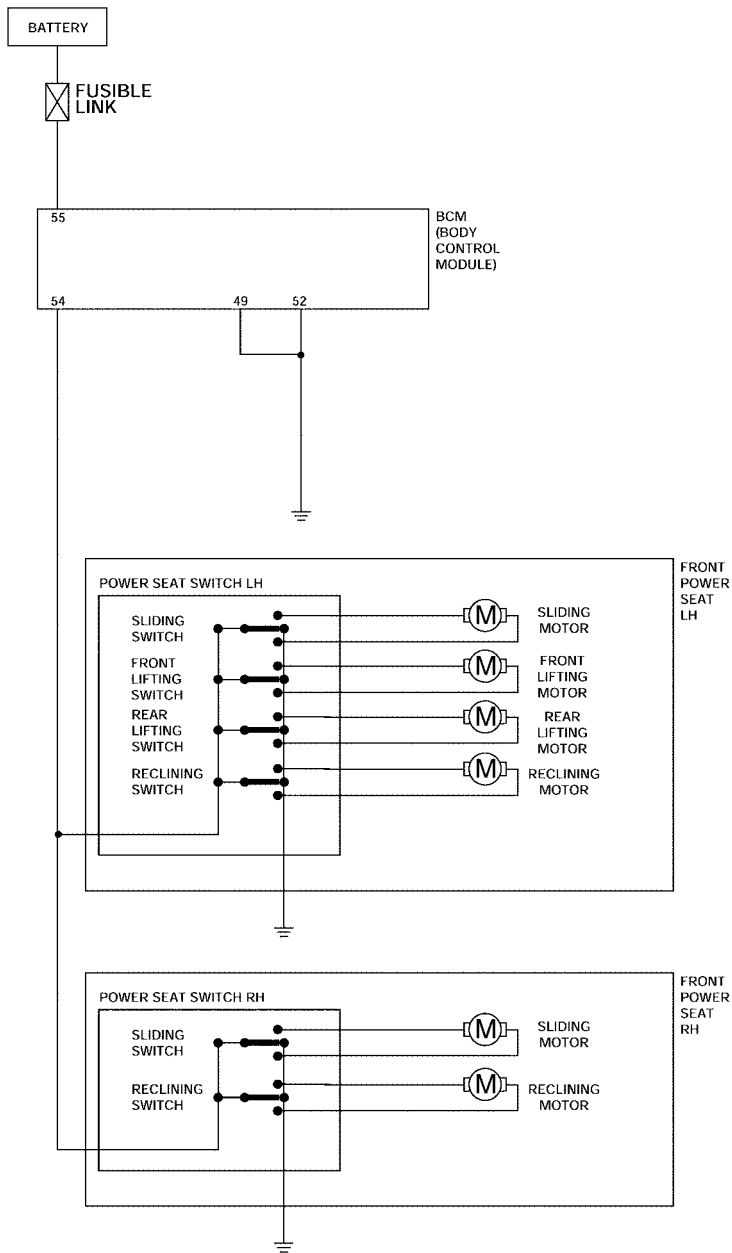

A

B

C

D

E

F

G

H

SE

J

K

L

M

POWER SEAT

Wiring Diagram-SEAT-

EIS001L8

SE-SEAT-01

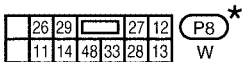
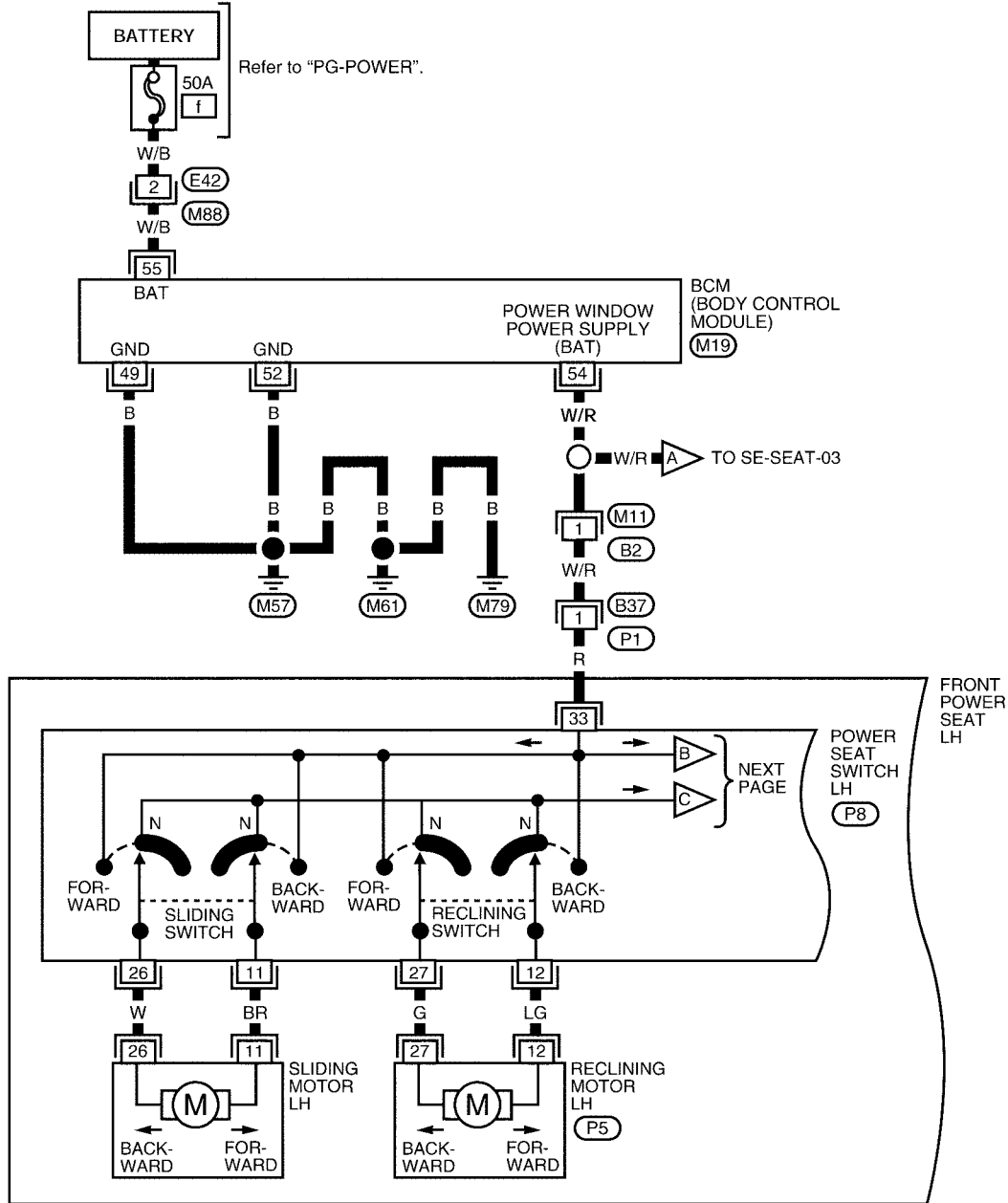

* : THIS CONNECTOR IS NOT SHOWN IN "HARNESS LAYOUT" OF PG SECTION.

LIWA0085E

POWER SEAT

SE-SEAT-02

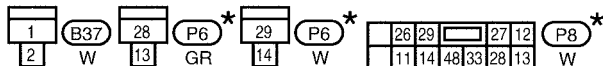
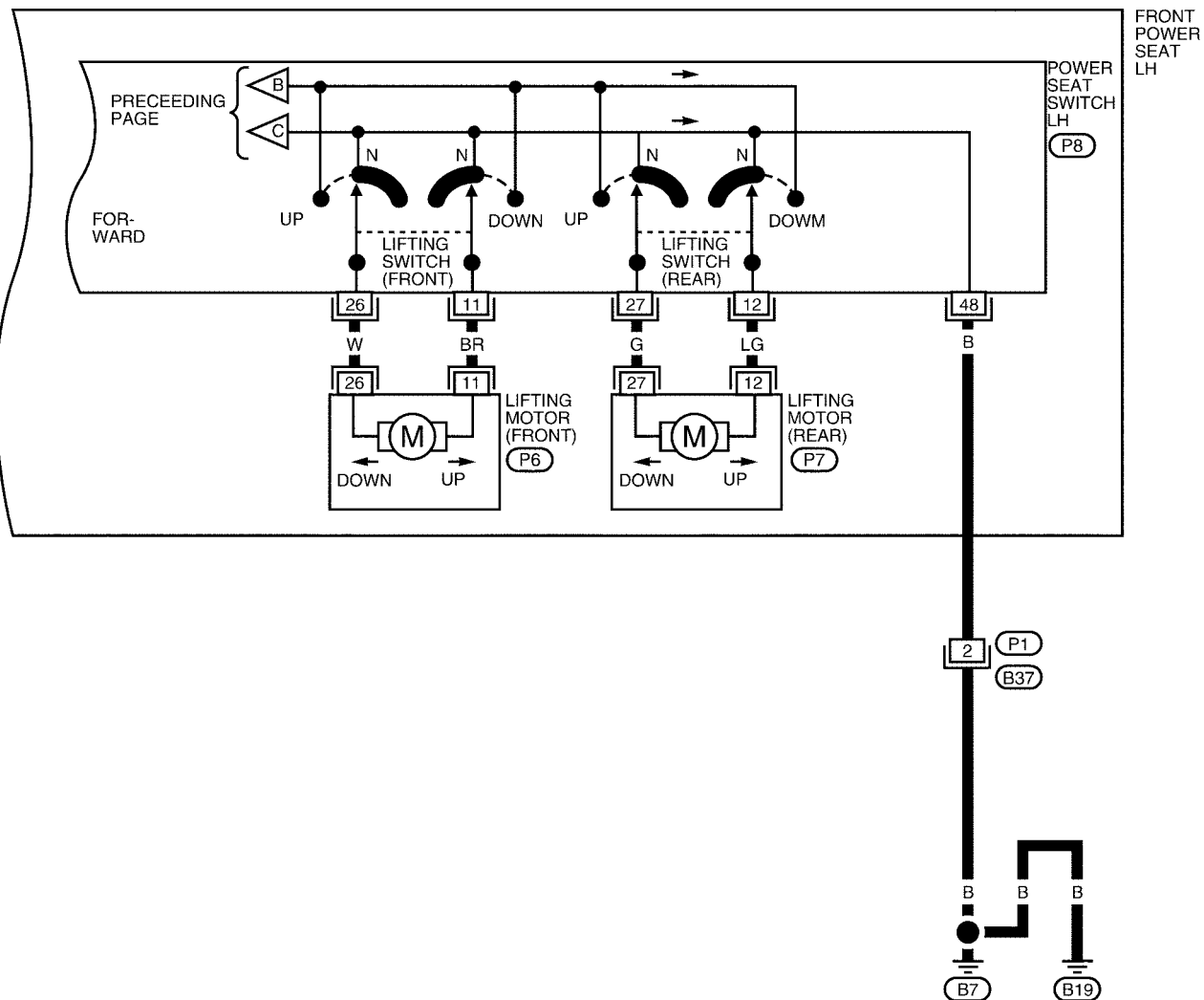

* : THIS CONNECTOR IS NOT SHOWN IN "HARNESS LAYOUT" OF PG SECTION.

LIWA0086E

POWER SEAT

SE-SEAT-03

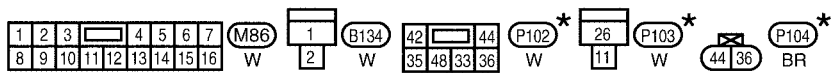
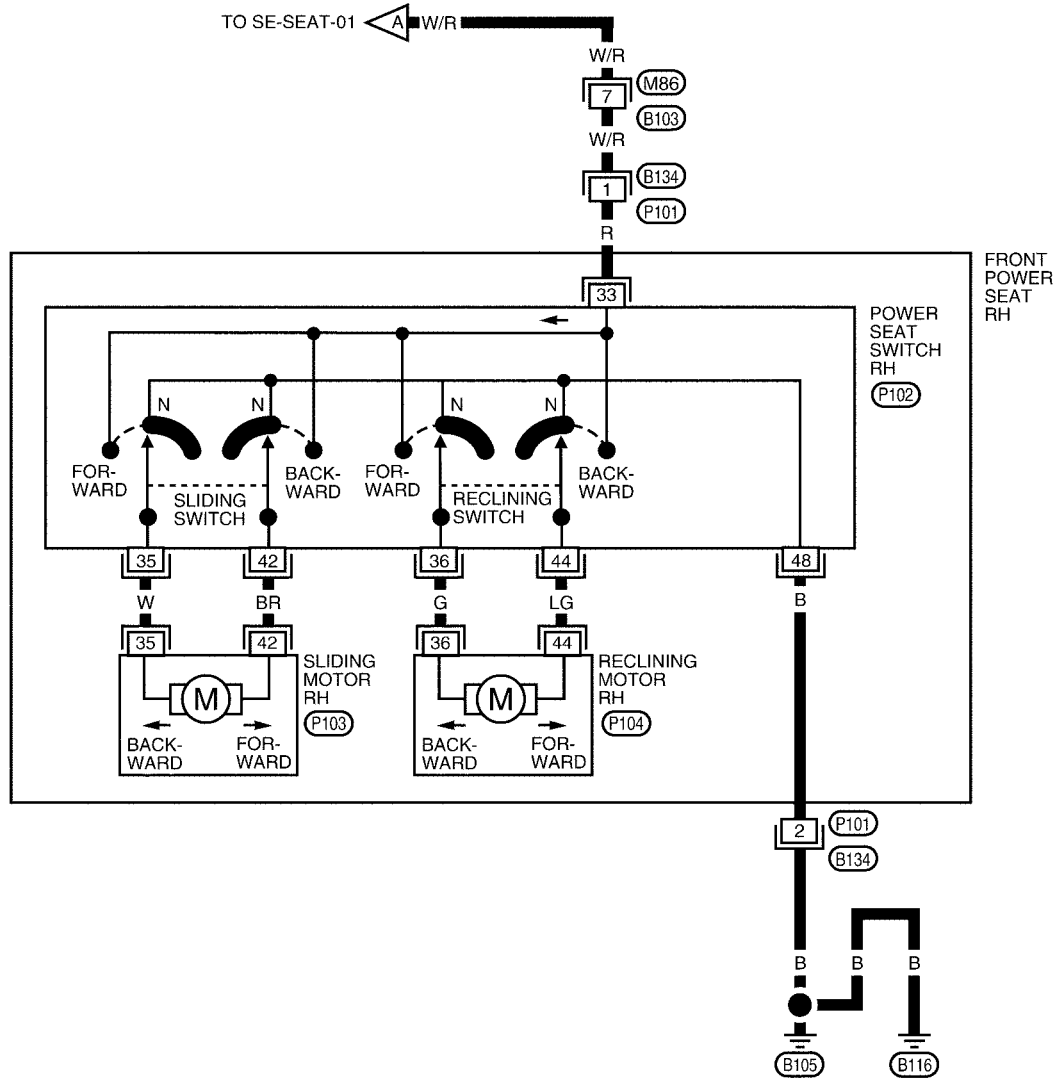

*: THIS CONNECTOR IS NOT SHOWN IN "HARNESS LAYOUT" OF PG SECTION.

LIWA0087E

HEATED SEAT

PFP:87335

HEATED SEAT

Description

EIS001L9

- When handling seat, be extremely careful not to scratch heating unit.
- To replace heating unit, seat trim and pad should be separated.
- Do not use any organic solvent, such as thinner, benzene, alcohol, etc. to clean trim.

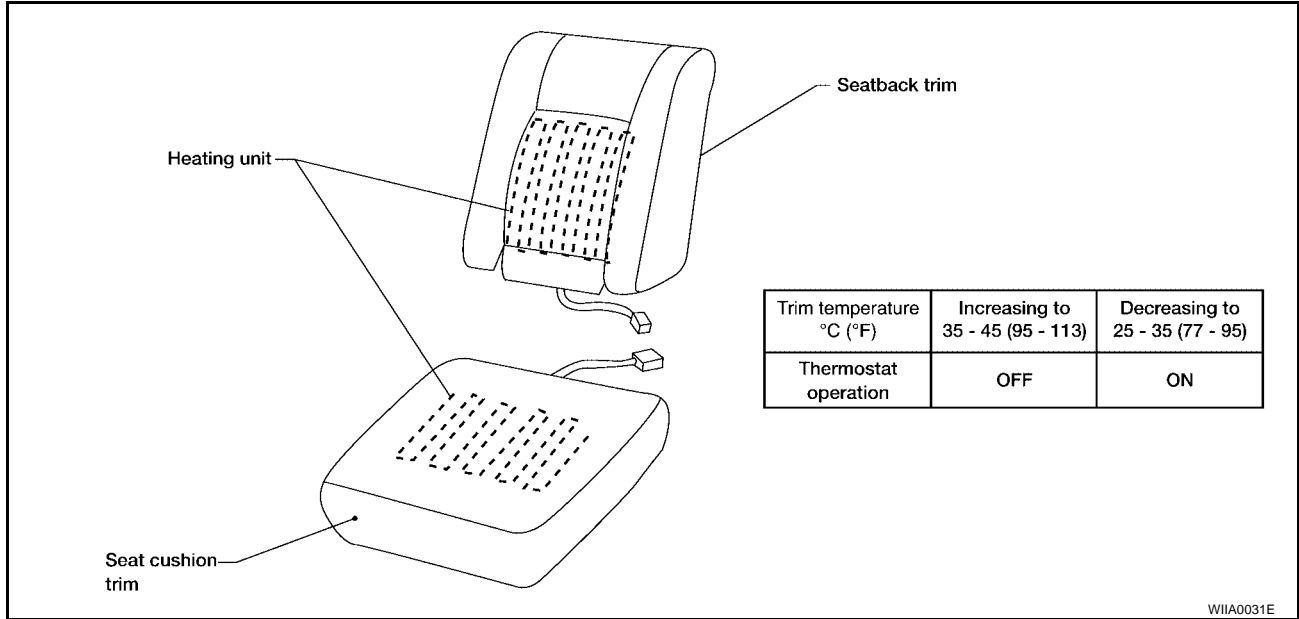

WIIA0031E

A
B
C
D
E
F
G
H
SE
J
K
L
M

HEATED SEAT

EIS00103

Schematic WITH FRONT LEFT AND RIGHT HEATED SEATS

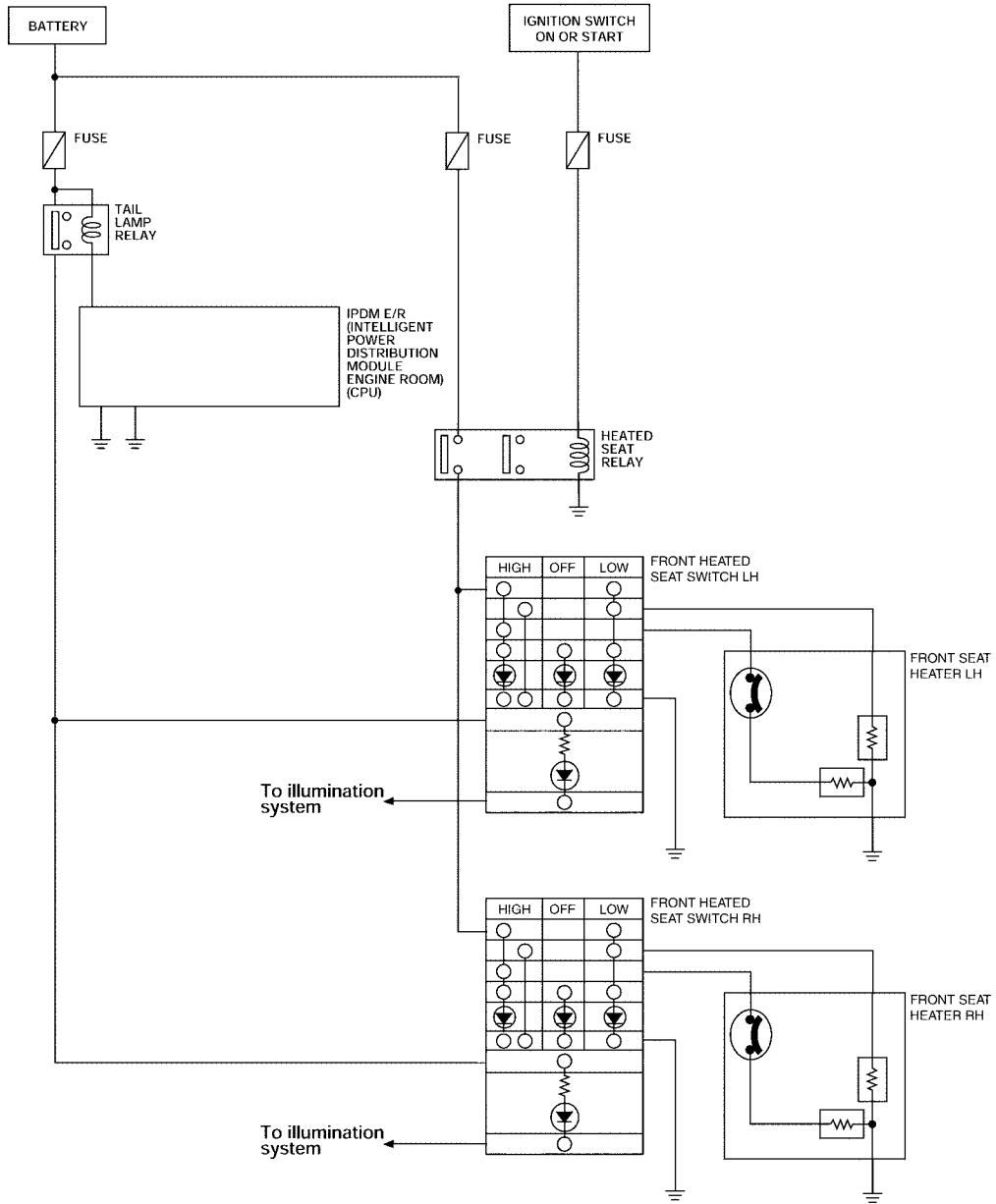

LJWA0088E

HEATED SEAT

WITH FRONT AND REAR HEATED SEATS

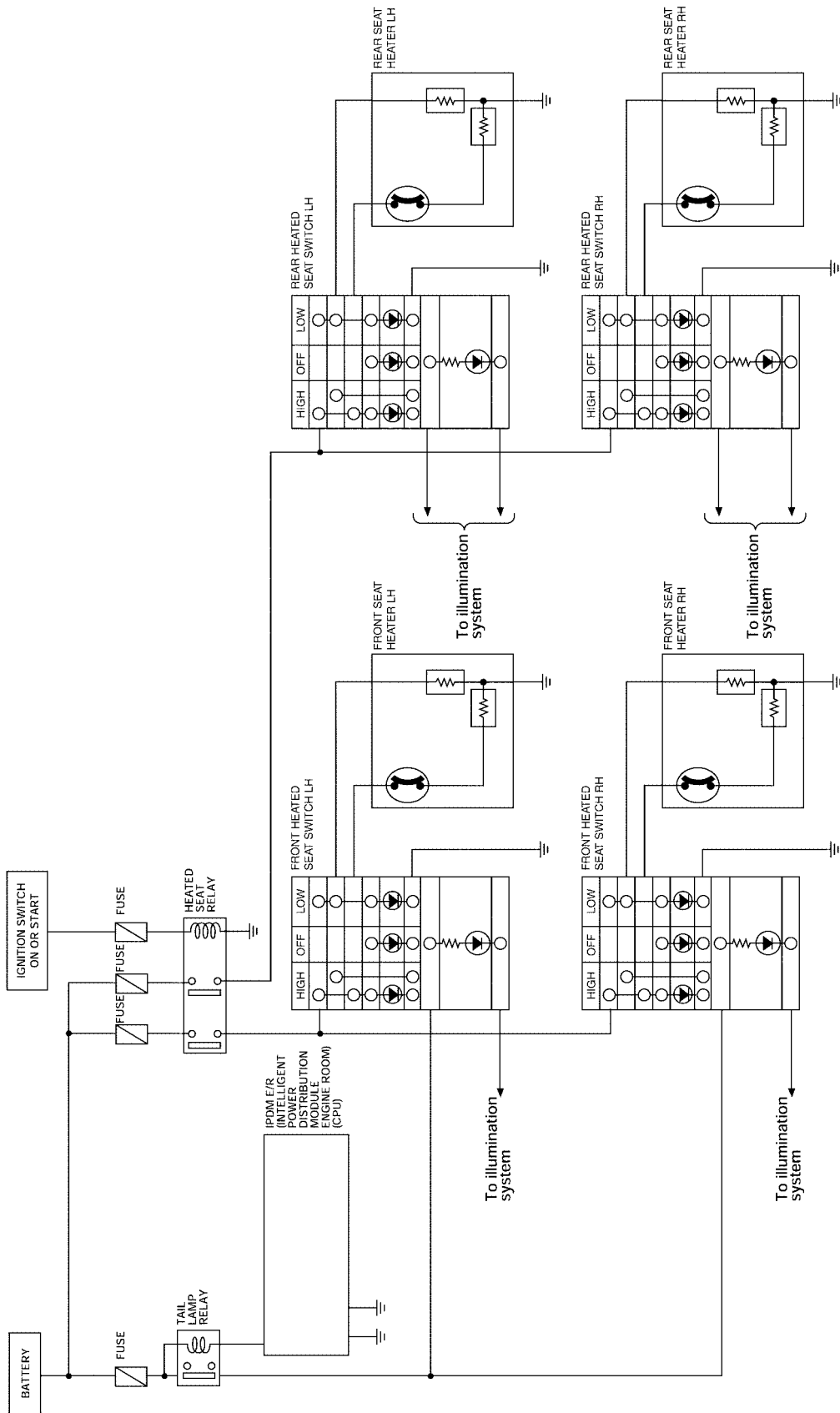

A
B
C
D
E
F
G
H
SE
J
K
L
M

HEATED SEAT

EIS001LA

Wiring Diagram—HSEAT— WITH FRONT LEFT AND RIGHT HEATED SEATS

SE-HSEAT-01

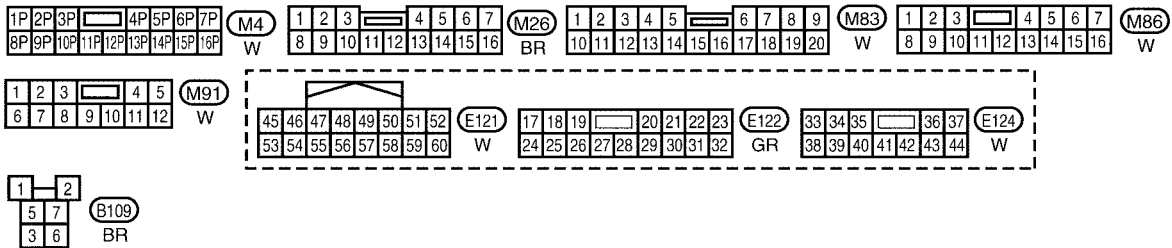
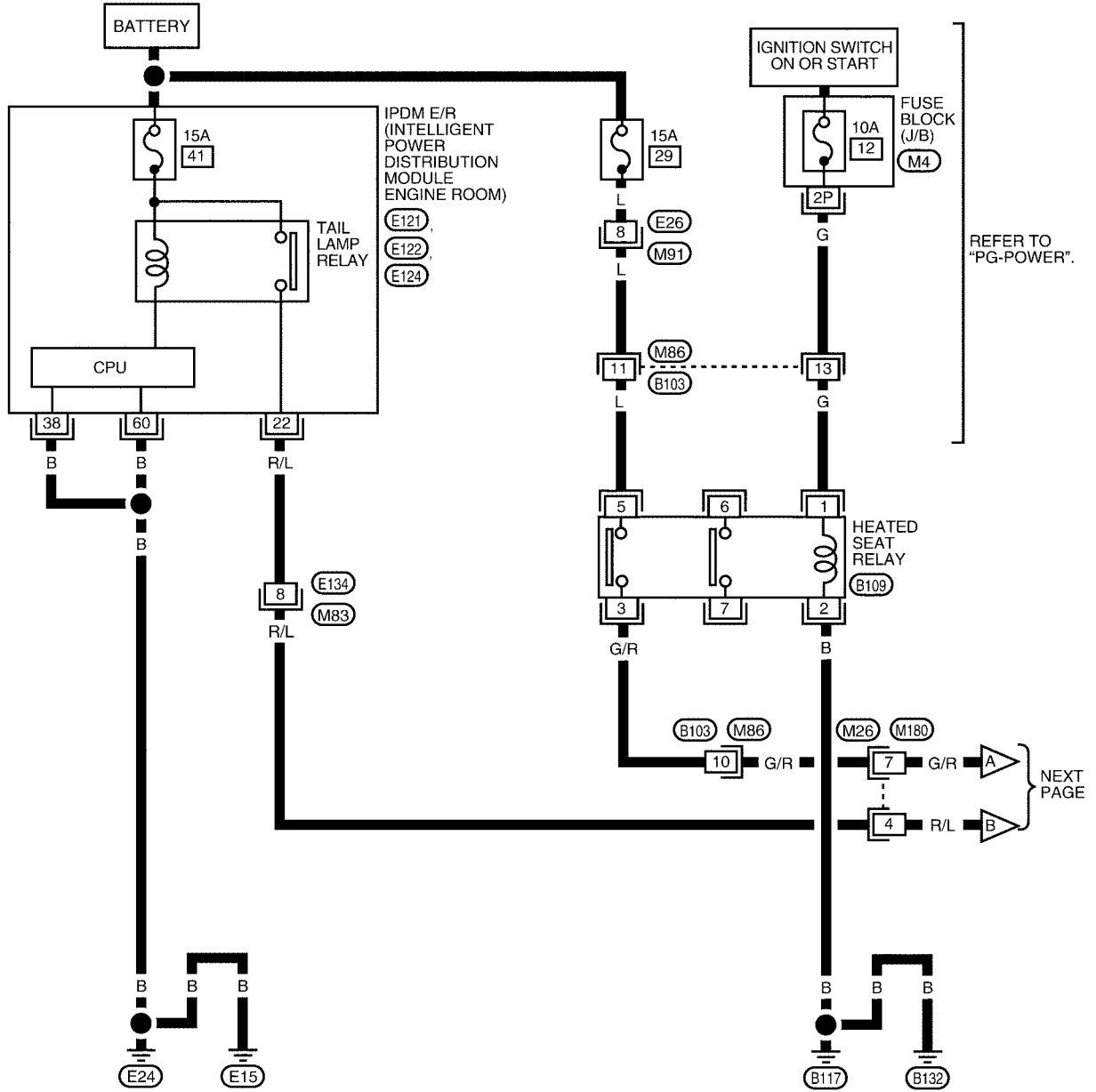

LIWA0090E

HEATED SEAT

SE-HSEAT-02

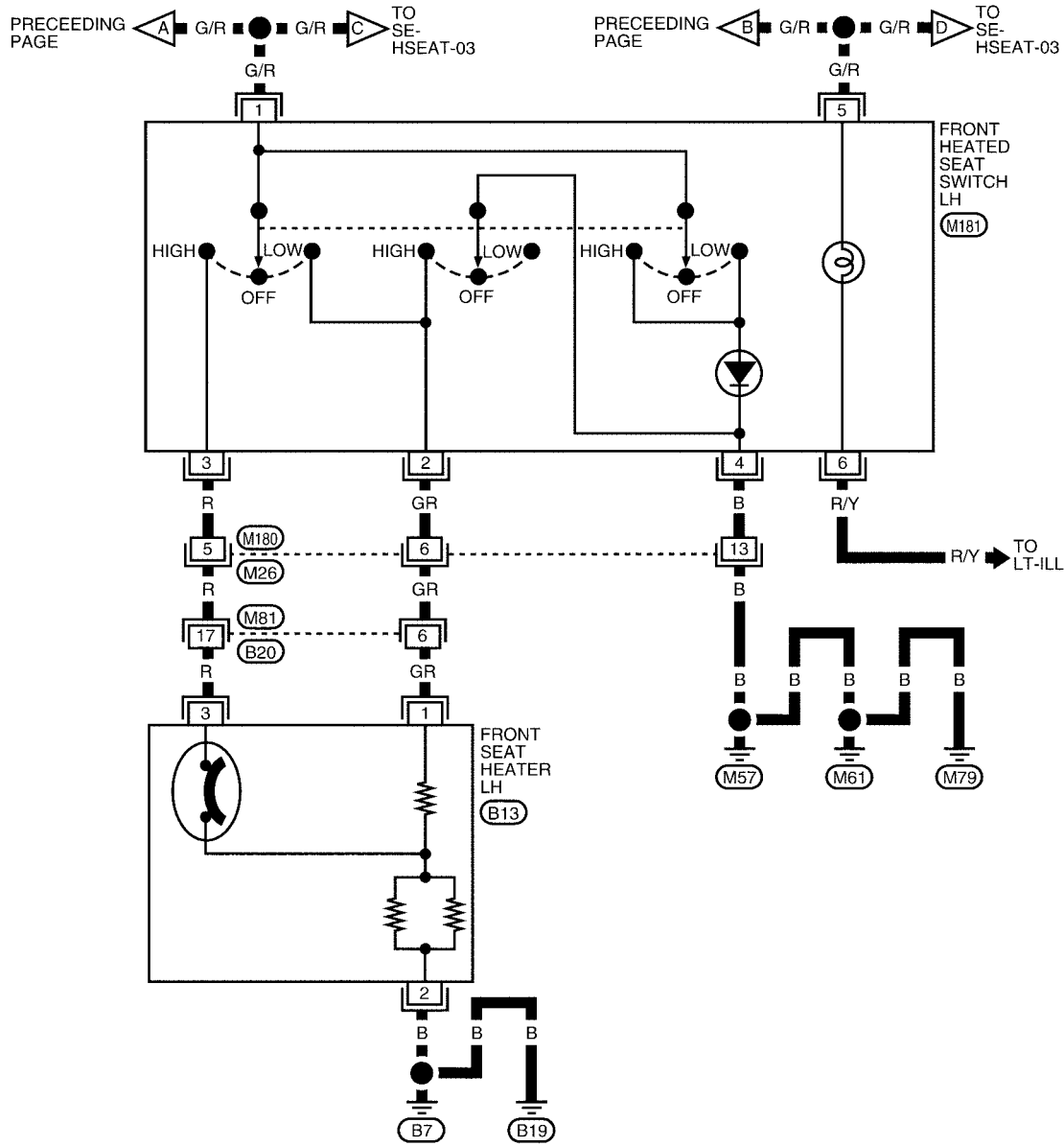

1	2	3	4	5	6	7	(M26)	1	2	3	4	5	6	7	8	9	(M81)	6	5	(M181)	1	(B13)							
8	9	10	11	12	13	14	15	16	BR	10	11	12	13	14	15	16	17	18	19	20	GR	3	1	2	4	BR	2	3	W

A
B
C
D
E
F
G
H
SE
J
K
L
M

HEATED SEAT

SE-HSEAT-03

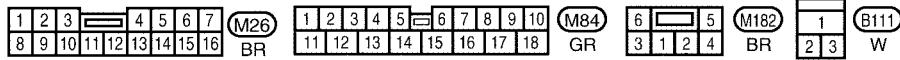
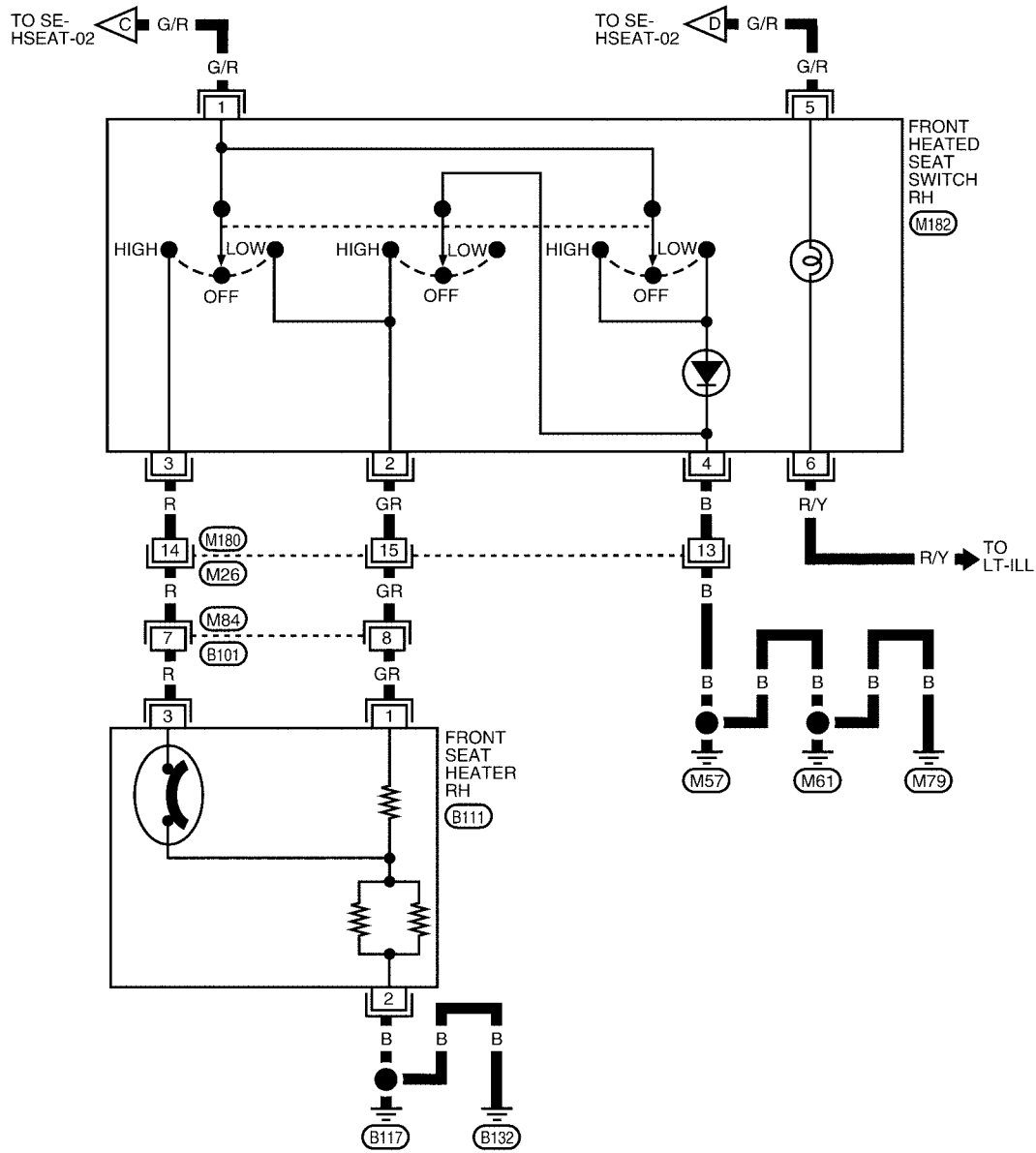

LIWA0092E

HEATED SEAT

WITH FRONT AND REAR HEATED SEATS

SE-HSEAT-04

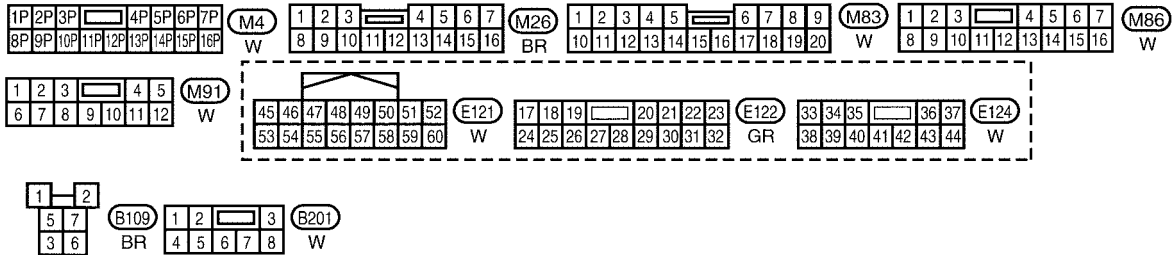
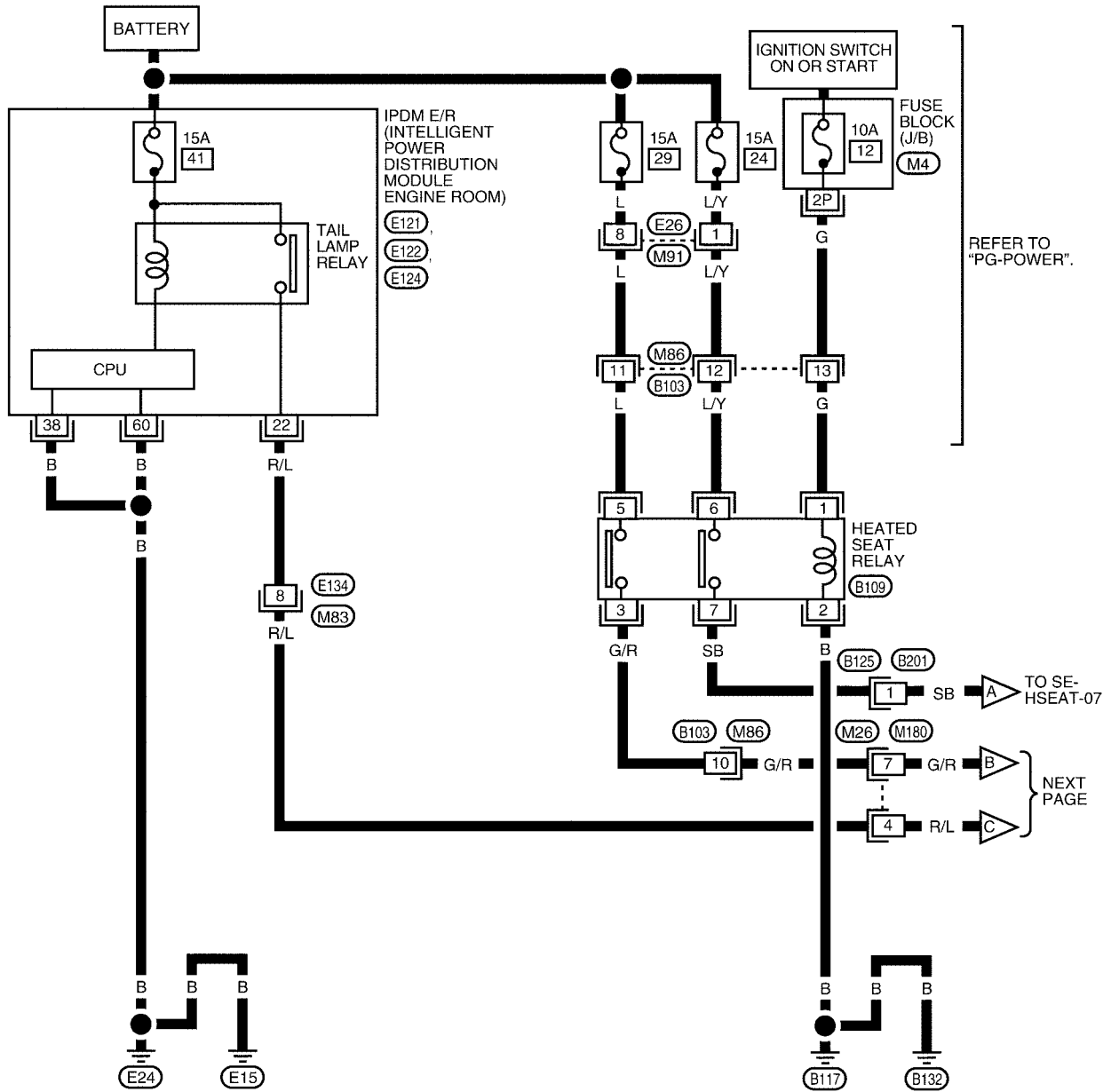

LIWA0093E

HEATED SEAT

SE-HSEAT-05

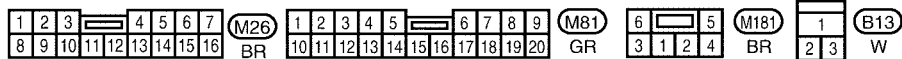
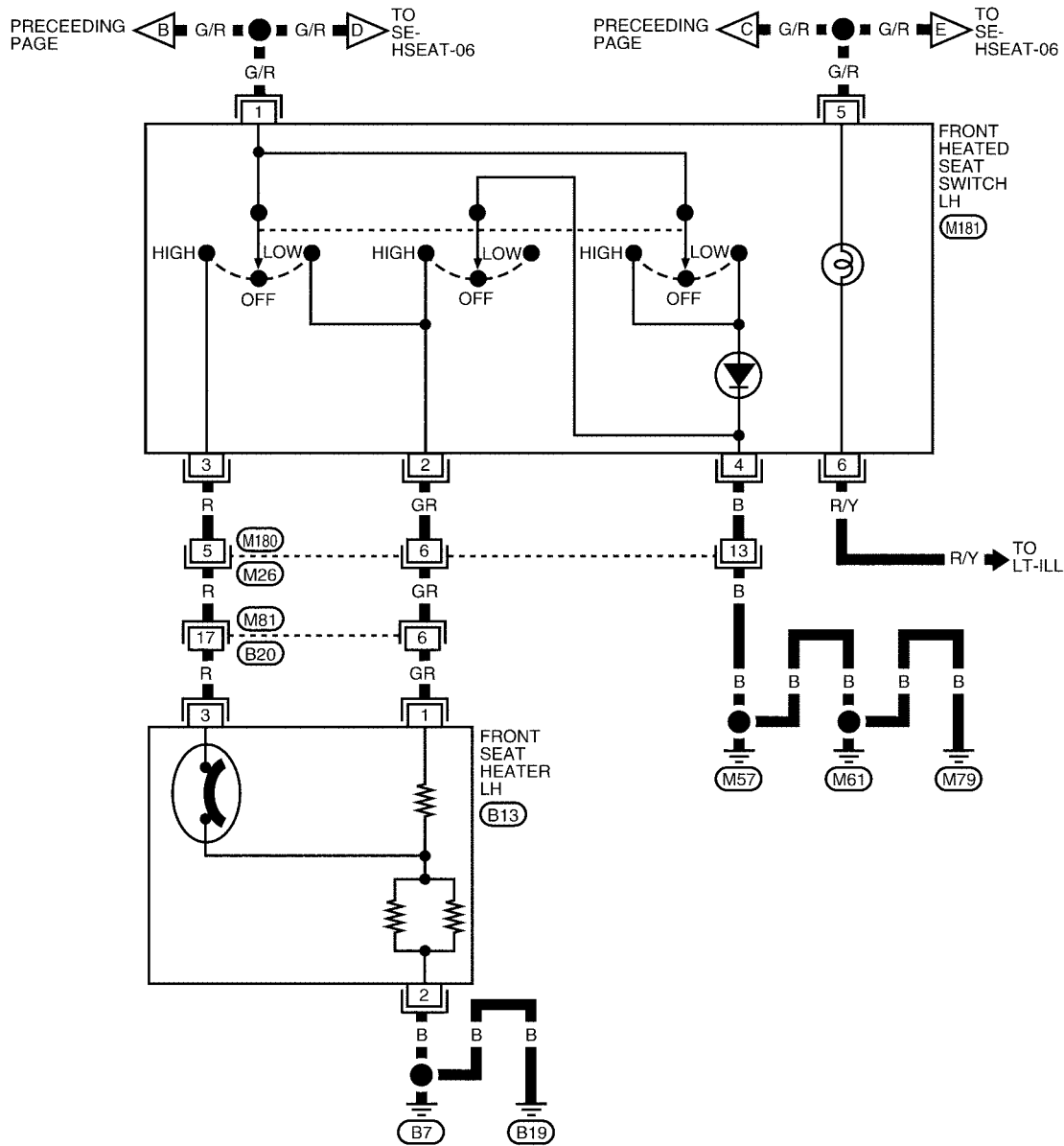

HEATED SEAT

SE-HSEAT-06

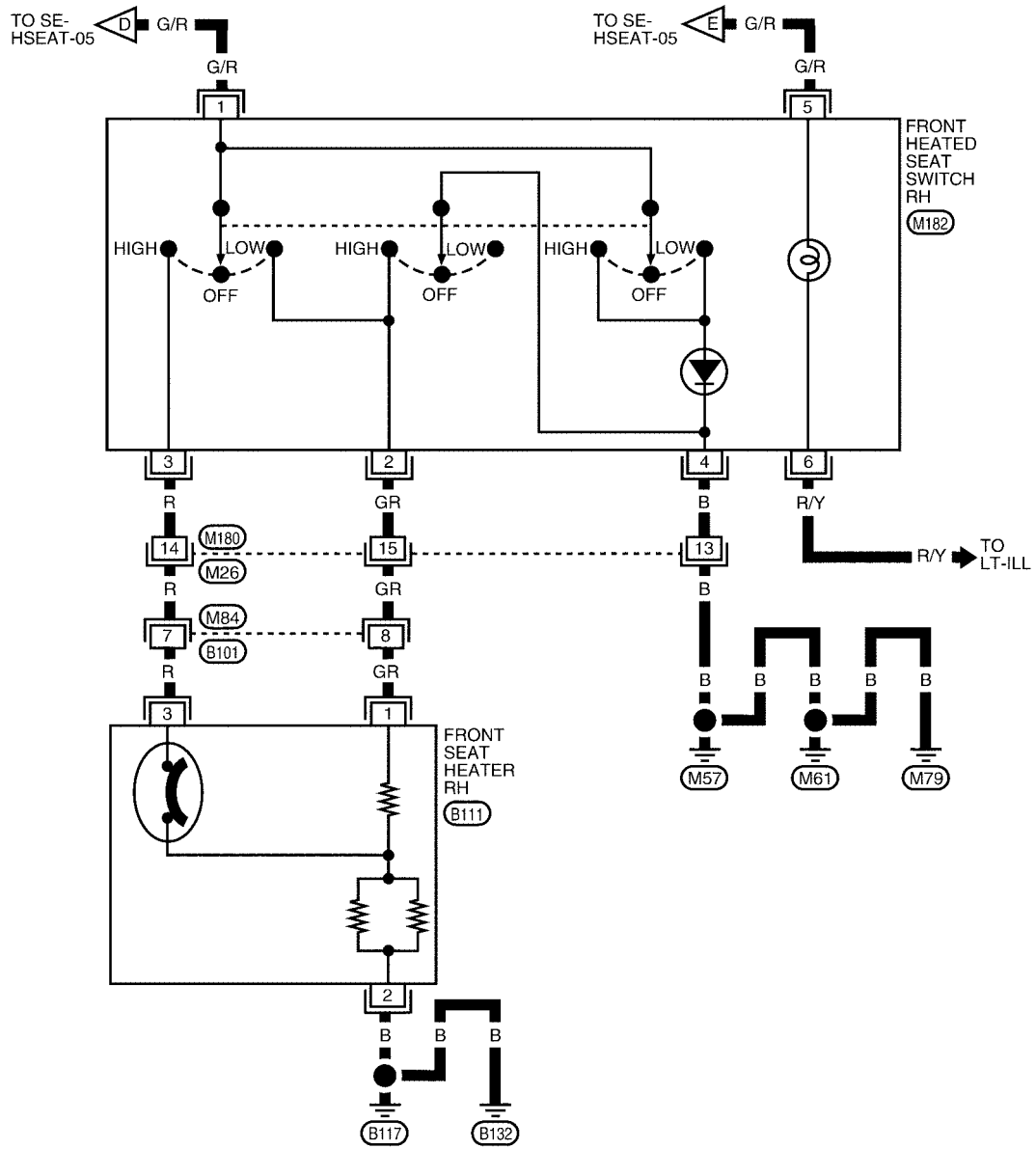

1	2	3	4	5	6	7	M26	1	2	3	4	5	6	7	8	9	10	M84	6	5	M182	1	B111
8	9	10	11	12	13	14	BR	11	12	13	14	15	16	17	18	GR	3	1	BR	2	W		

A
B
C
D
E
F
G
H
SE
J
K
L
M

LIWA0095E

HEATED SEAT

SE-HSEAT-07

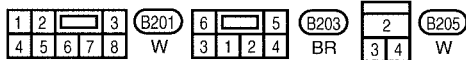
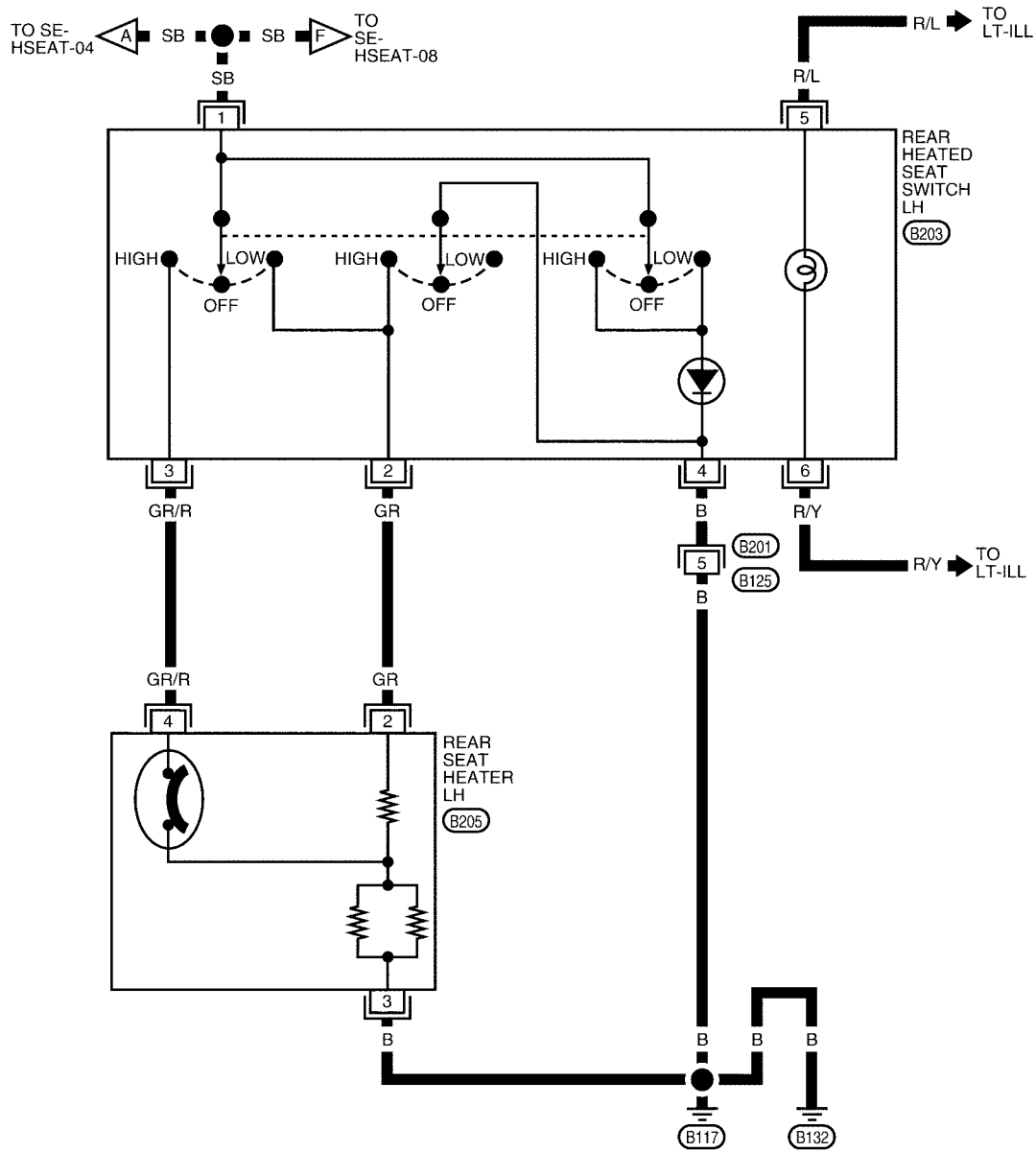

LIWA0096E

FRONT SEAT

PFP:87000

EIS001LB

FRONT SEAT

Removal and Installation

Driver Seat

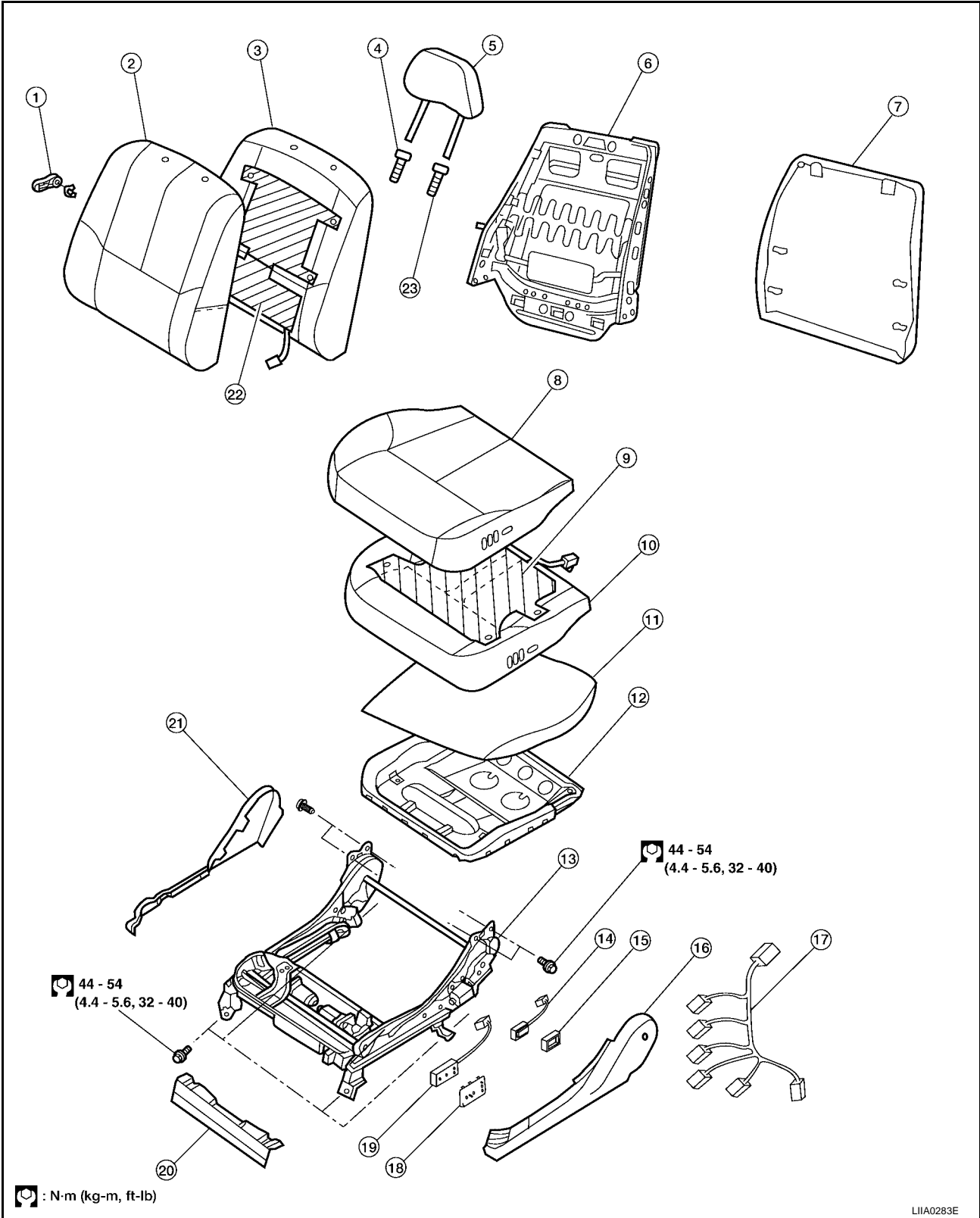

LIA0283E

- | | | |
|---------------------------|----------------------|-----------------------------|
| 1. Seat lumbar unit lever | 2. Seatback trim | 3. Seatback pad |
| 4. Headrest holder (free) | 5. Headrest | 6. Seatback frame |
| 7. Seatback board | 8. Seat cushion trim | 9. Seat cushion heater unit |

FRONT SEAT

10. Seat cushion pad	11. Silk film bag	12. Seat cushion frame	
13. Driver seat frame assembly	14. Power lumbar support switch (optional)	15. power lumbar support switch finisher	A
16. Seat cushion outer finisher	17. Driver power seat harness	18. power seat switch finisher	
19. Power seat switch	20. Seat cushion front finisher	21. Seat cushion inner finisher	B
22. Seatback heater unit	23. Headrest holder (locked)		

C

D

E

F

G

H

SE

J

K

L

M

FRONT SEAT

Passenger Seat

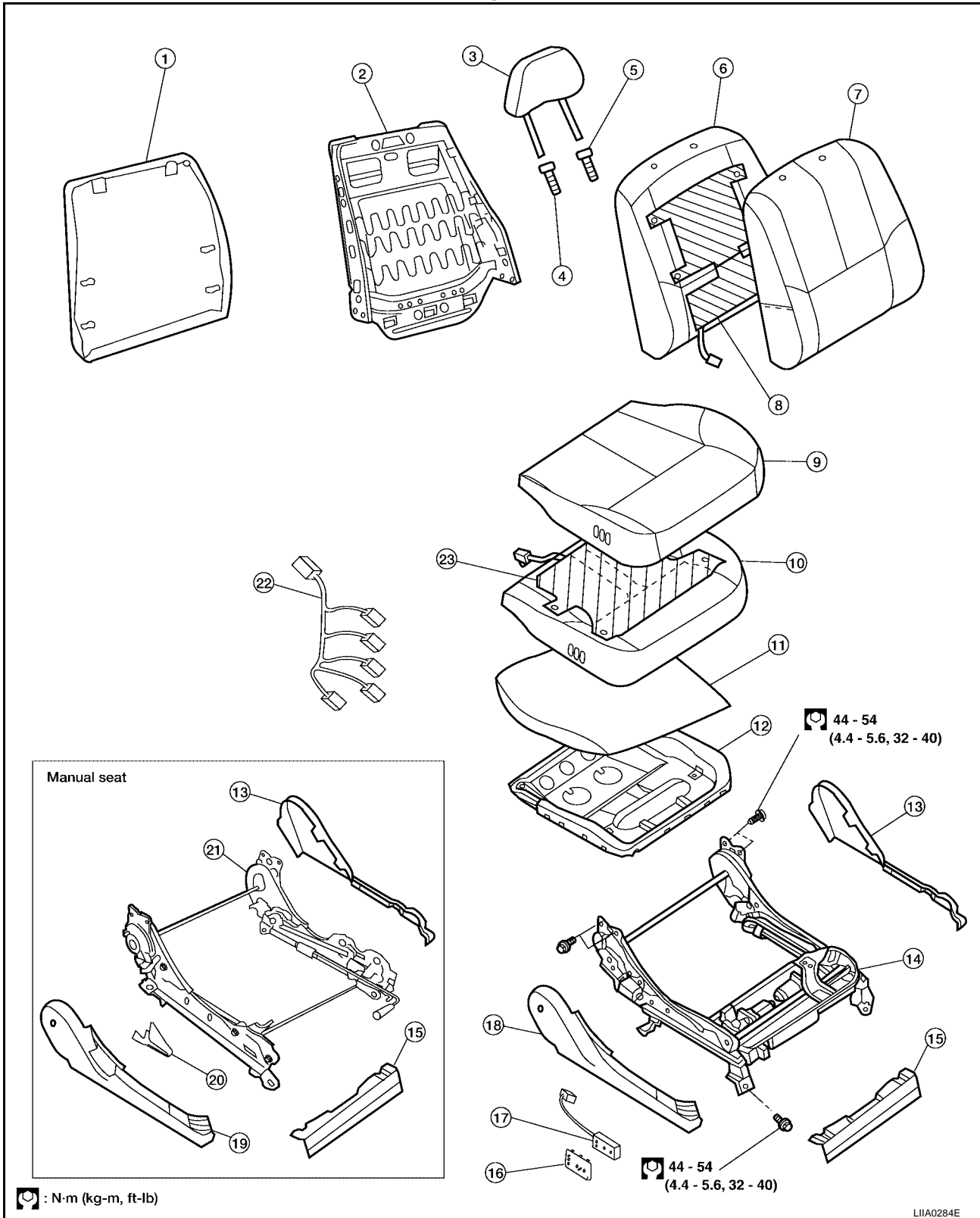

: N-m (kg-m, ft-lb)

44 - 54
(4.4 - 5.6, 32 - 40)

LIA0284E

- | | | |
|---------------------------------|---|---------------------------------|
| 1. Seat back board | 2. Seatback frame | 3. Headrest |
| 4. Headrest holder (free) | 5. Headrest holder (locked) | 6. Seatback pad |
| 7. Seatback trim | 8. Seatback heater unit | 9. Seat cushion trim |
| 10. Seat cushion pad | 11. Silk film bag | 12. Seat cushion frame |
| 13. Seat cushion inner finisher | 14. Passenger seat power frame assembly | 15. Seat cushion front finisher |

FRONT SEAT

- | | | | |
|---|------------------------------------|--|---|
| 16. Power seat switch finisher | 17. Power seat switch | 18. Seat cushion outer finisher (power seat) | A |
| 19. Seat cushion outer finisher (manual seat) | 20. Seatback manual recline handle | 21. Passenger seat manual frame assembly | B |
| 22. Passenger power seat harness | 23. Seat cushion heater unit | | C |

REMOVAL

When removing or installing the seat trim, handle it carefully to keep dirt out and avoid damage.

CAUTION:

- Before removing the front seat, turn the ignition switch off, disconnect both battery cables and wait at least 3 minutes.
 - When checking the power seat circuit for continuity using a circuit tester, do not confuse its connector with the side air bag module connector. Such an error may cause the air bag to deploy.
 - Do not drop, tilt, or bump the side air bag module while installing the seat. Always handle it with care.
 - After front side air bag module inflates, front seatback assembly must be replaced.
1. Slide the seat until the four body mounting bolts are visible and a tool can be inserted.

NOTE:

- When disassembling the driver seat after removal, set the front/rear cushion lifter to the top position.
2. Disconnect both battery cables and wait at least 3 minutes.
 3. Remove the harness connector for the side air bag module.
 4. Remove the four body mounting bolts.
 5. Remove the power seat harness connector and vehicle harness fixing clip from the vehicle.

NOTE:

When removing and installing, use shop cloths to protect the parts from damage where they may interfere with other parts.

INSTALLATION

- Install in the reverse order of removal.

NOTE:

Be sure to insert the rear end tab of the rear leg cover under the rail.

Disassembly and Assembly SEATBACK TRIM AND PAD

EIS001LC

WARNING:

Removal of front side air bag module should only be done to allow deployment of front side air bag module prior to disposal of seatback assembly.

NOTE:

Only complete seatback assemblies can be replaced on vehicles equipped with side air bags.

NOTE:

Be sure to set the front/rear cushion lifter to the top position.

1. Remove the seatback board from the back of the seatback.

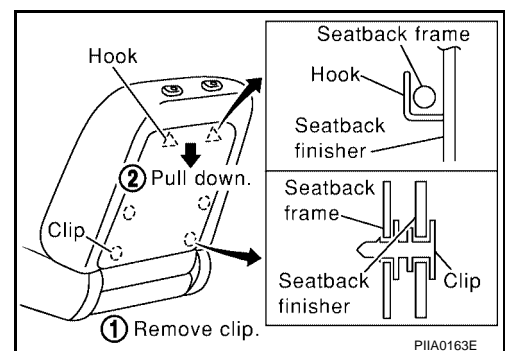

FRONT SEAT

- From the back of the seatback, press the headrest holder tabs at the base of the stay pipe to disengage. Then pull the headrest holder up to remove.

NOTE:

Before installing the headrest holder, check its orientation (front/rear and right/left).

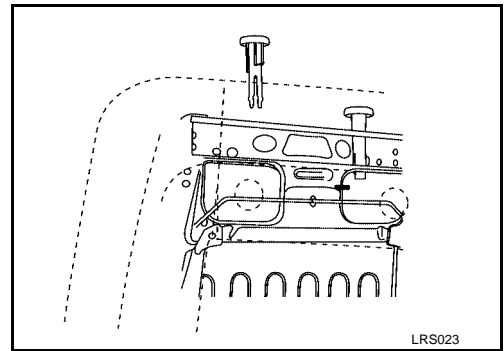

- Remove the retainer.

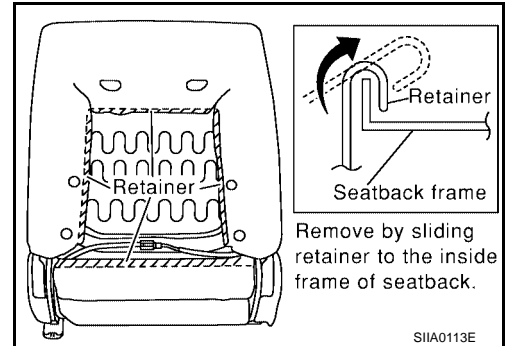

- Remove the seat heater harness connector. After removing the seatback trim and pad, remove the hog ring to separate the trim from the pad and the seatback heater unit.

REMOVAL OF SEATBACK ASSEMBLY

- After completing the steps 1 and 2 of "Seatback Trim and Pad", remove the harness connectors for the reclining motor and lumbar support motor (driver seat only).
- Pull out the harness connector for the side air bag from the seat cushion.
- Remove the reclining device mounting bolts (2 for each side) on the seatback frame, and remove the seatback assembly.

NOTE:

When assembling the seatback frame, make sure that the reclining device is locked on both sides, and be sure to temporarily tighten the bolts, then finish tightening them.

INSTALLATION OF SEATBACK ASSEMBLY

- Install in the reverse order of removal.

SEAT CUSHION TRIM AND PAD

- Remove the power seat switch knob (or recline knob on manual seat).
- Remove the front seat cushion finisher (inner).

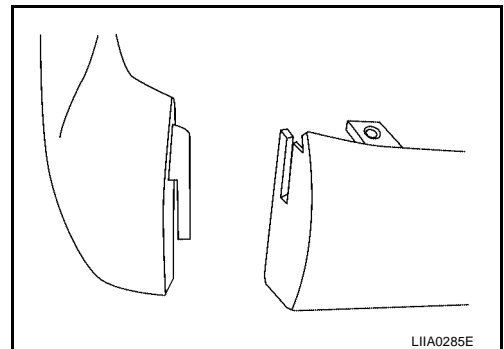

- Remove the three power seat switch assembly screws (or lift knobs on manual seats).

FRONT SEAT

4. Remove four bolts retaining the seat cushion assembly, remove seat cushion assembly.

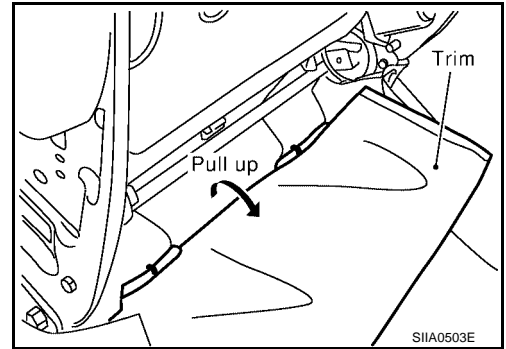

5. Remove the retainer on the seat cushion frame, then remove the harness connector for the seat heater.
6. After removing the seat cushion trim and pad, remove the hog rings to separate the trim from the pad and seat cushion heater unit.

A
B
C
D
E
F
G
H
SE
J
K
L
M

REAR SEAT

REAR SEAT

PFP:88300

Removal and Installation

EIS001LD

REMOVAL

1. Pull the lock at the front bottom of the seat cushion forward (1 for each side), and pull the seat cushion upward to release the wire from the plastic hook, then pull the seat cushion forward to remove.
2. Remove the RH and LH screws on the seatback.
3. Slide the seatback upward to pull off the wire from the wire from the vehicle-side hook, and remove the seatback.
4. After removing, remove the hog ring to separate the trim and pad.

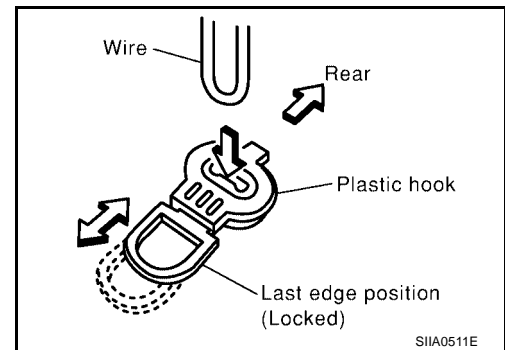

INSTALLATION

- Install in the reverse order of removal.

REAR SEAT

Disassembly and Assembly

EIS001LE

5-Passenger

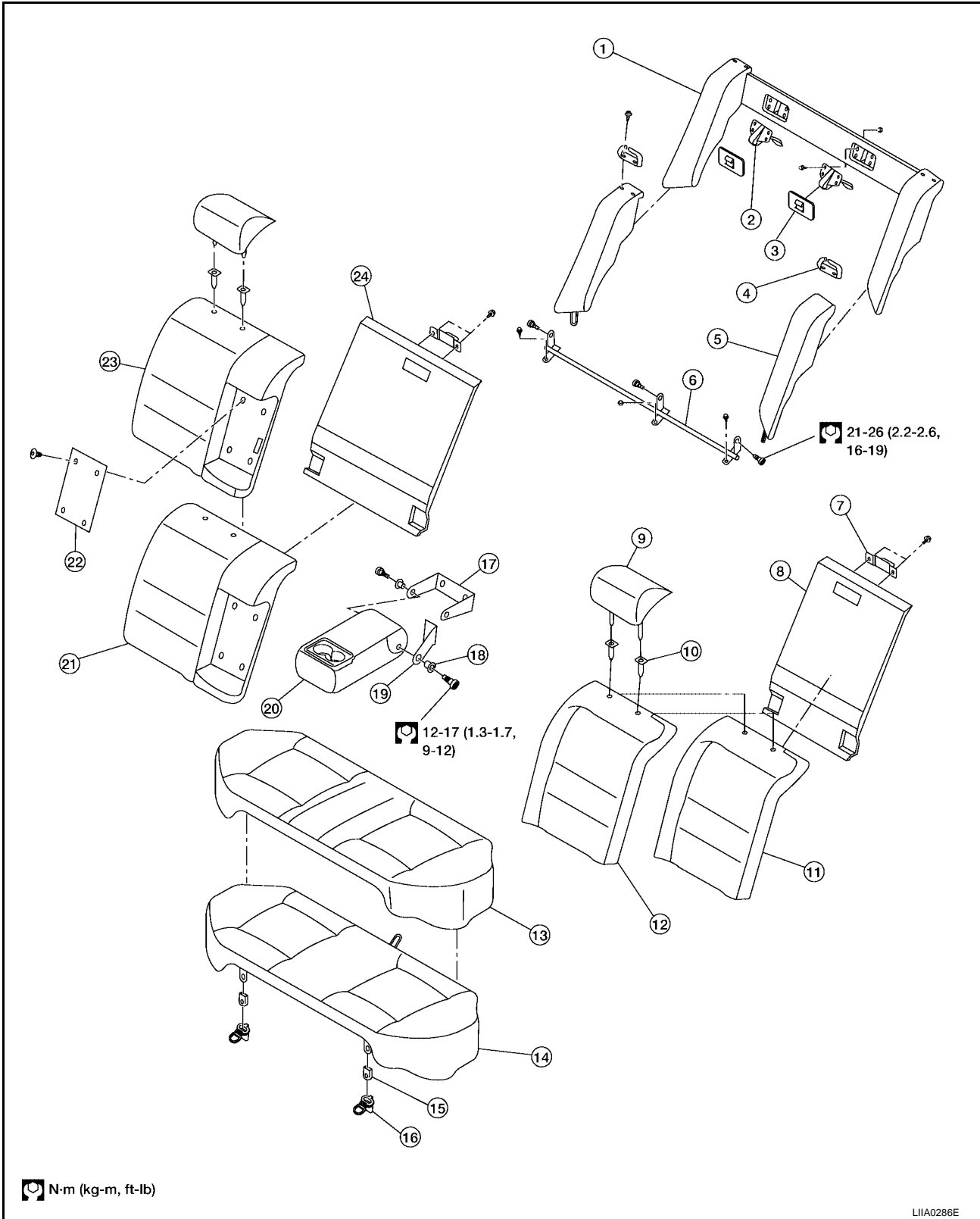

A
B
C
D
E
F
G
H
SE
J
K
L
M

- | | | |
|------------------------------------|---|--|
| 1. Rear seat side bolster assembly | 2. Rear seatback latch assemblies | 3. Rear seatback latch covers |
| 4. Seat belt guides | 5. Rear seatback side bolster trim covers | 6. Rear seatback hinge assembly covers |
| 7. Rear seatback latch strikers | 8. Rear seatback board (40 percent portion) | 9. Rear seatback headrest |

REAR SEAT

- | | | |
|----------------------------------|---|---|
| 10. Headrest guide | 11. Rear seatback pad (40 percent portion) | 12. Rear seatback trim cover (40 percent portion) |
| 13. Rear seat cushion trim cover | 14. Rear seat cushion pad and frame | 15. Rear seat cushion hook insulator |
| 16. Rear seat cushion hook | 17. Armrest bracket | 18. Bushing |
| 19. Armrest bracket cover | 20. Rear seat armrest assembly | 21. Rear seatback pad (60 percent portion) |
| 22. Armrest lid board assembly | 23. Rear seatback trim cover (60 percent portion) | 24. Rear seatback board (60 percent portion) |

REAR SEAT

4-Passenger

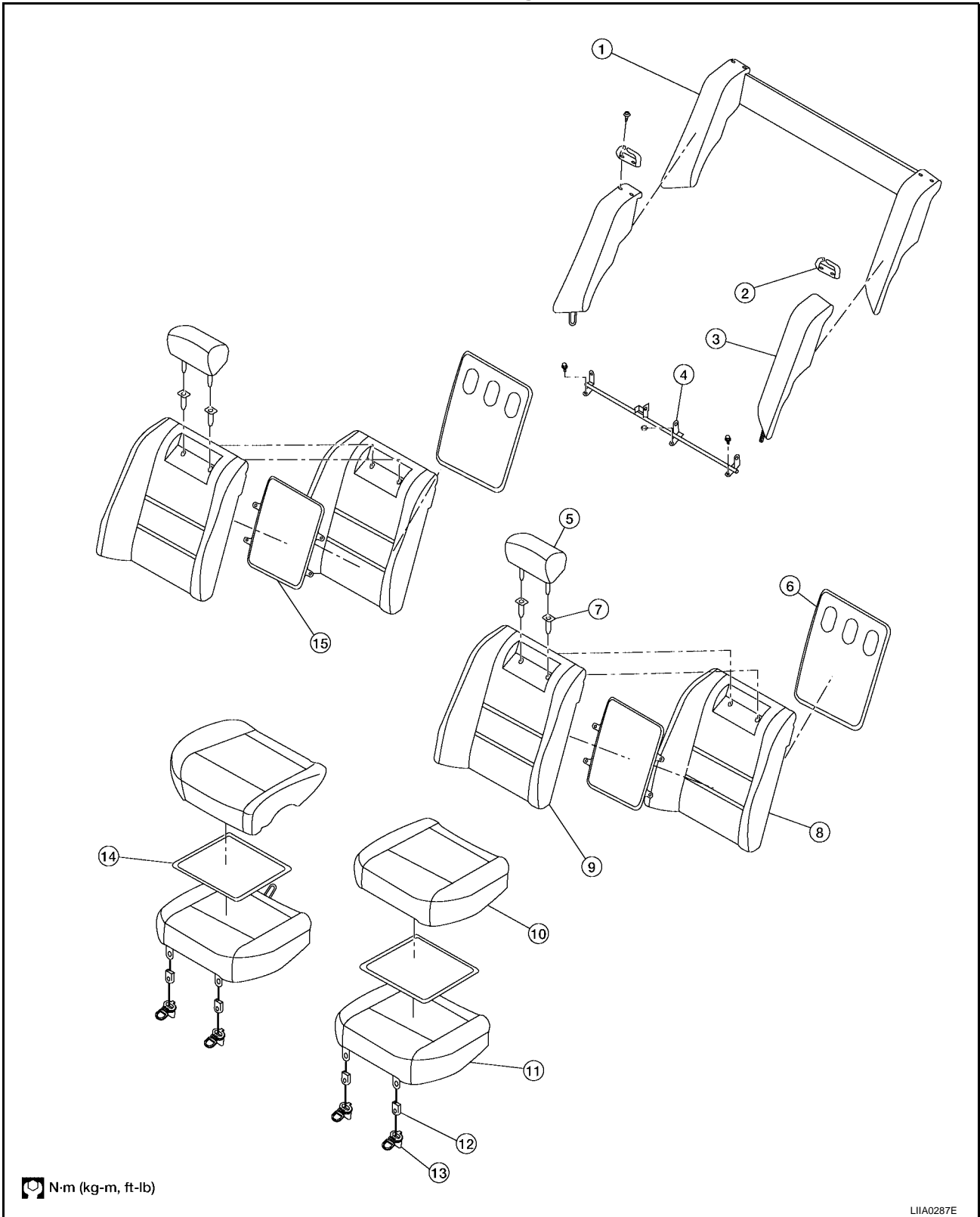

- | | | |
|------------------------------------|-------------------------------------|---|
| 1. Rear seat side bolster assembly | 2. Seat belt guide | 3. Rear seatback side bolster trim covers |
| 4. Rear seatback hinge assembly | 5. Rear seatback headrest | 6. Rear seatback board |
| 7. Headrest guide | 8. Rear seatback pad | 9. Rear seatback trim cover |
| 10. Rear seat cushion trim cover | 11. Rear seat cushion pad and frame | 12. Rear seat cushion hook insulator |
| 13. Rear seat cushion hook | 14. Rear seat cushion heater | 15. Rear seat back heater |

REAR SEAT
